

Preface

Product Presentation

The EL10H is a compact, versatile VFD featuring a streamlined design and comprehensive hardware/software configuration. With its agile, user-friendly, and reliable performance, it is primarily designed for speed regulation of three-phase AC asynchronous motors. Widely used in industries such as food and beverage, logistics packaging, textiles, and woodworking machinery, the product's appearance is illustrated in the following image.

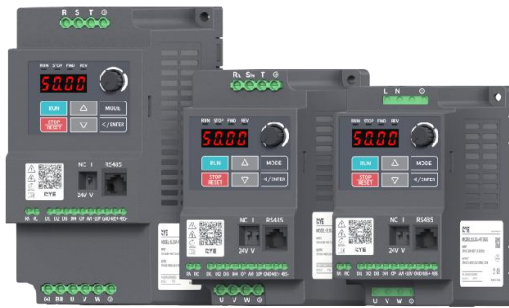

This manual introduces the installation, wiring, debugging and trial operation of the product, including installation dimensions, mechanical installation, electrical installation, debugging and trial operation, troubleshooting, function code table, peripheral electrical components, etc.

Version Change Log

Revision Date	Release Version	Change Content
2025-09	1.0	First release
2026-02	2.0	New release of 3PH 380V 7.5~11kW & 1PH 4.0kW.
2026-04	2.1	New release of 3PH 380V 15kW.

Warranty Statement

- Under normal usage, if the product malfunctions or is damaged, we provide warranty service during the warranty period. After the warranty period, repair costs will be charged.
- During the warranty period, repair costs will be charged for product damage caused by the following situations.
 - Failure to operate this product in accordance with the manual may result in product damage.
 - Product damage caused by fire, flood, or abnormal voltage.
 - Use of this product for abnormal functions may cause product damage.
 - Product damage caused by exceeding the specified usage scope.
- Secondary damage to products caused by force majeure (natural disasters, earthquakes, or lightning strikes).

Service fees are calculated according to the manufacturer's unified standards. In case of any contract, the contract terms take precedence. For detailed warranty information, please refer to the “Product Warranty Card”.

Safety Precautions

Security Statement

- This chapter outlines the safety precautions required for proper use of this product. Before using the product, please read the product manual and fully understand the relevant safety precautions. Failure to comply with the specified safety precautions may result in fatalities, severe injuries, or equipment damage.
- The "Hazard" and "Caution" items in the manual do not represent all the safety matters that should be observed, but are only intended to supplement all safety considerations.
- This product must be used in an environment that meets the specified design requirements. Failure to comply may cause malfunctions, and any functional abnormalities or component damage resulting from non-compliance will not be covered by the product's warranty.
- Our company shall not be held liable for any personal injury or property damage resulting from non-compliance with this manual or improper operation of the product.

Security definition

In this manual, safety precautions are divided into the following two categories:











Hazard: Risk of serious injury or death due to failure to follow instructions;



Note: The risk of not following the instructions may result in moderate or minor injuries, and damage to equipment.

When installing, debugging, or maintaining this system, users must carefully read this chapter and strictly follow the safety precautions outlined herein. Any injuries or losses resulting from improper operations shall not be the responsibility of our company.

Usage Phase	Security Classification	Item
Before installation	 Danger	Do not install if the control system is found to be waterlogged, missing parts, or damaged upon opening the box. Do not install if the packing list does not match the product name.
	 Caution	Handle with care during transportation to avoid equipment damage. Do not use VFDs with damage or missing parts. There is a risk of injury! Do not touch the control system components with your hands, as this may cause electrostatic damage!

Usage Phase	Security Classification	Item
During installation	 Danger	Install on flame-retardant materials like metal and keep away from flammable objects. Otherwise, it may cause a fire! Do not arbitrarily turn the fixing bolts of equipment components, especially those marked with red!
	 Caution	Do not let wire ends or screws fall into the drive, as this may cause damage! Install the drive in a place with minimal vibration and avoid direct sunlight. When installing two or more VFDs in the same cabinet, ensure proper placement to maintain effective heat dissipation.
During wiring	 Danger	This must be performed by certified electrical engineers; otherwise, serious hazards may occur! A circuit breaker must be installed between the VFD and the power supply to prevent fire hazards. Before wiring, ensure the power supply is at zero energy level. Otherwise, there is a risk of electric shock! Connect the VFD to ground properly according to standard specifications, otherwise there is a risk of electric shock!
	 Caution	Never connect the input power to the VFD's output terminals (U, V, W). Always check the terminal markings to avoid incorrect wiring, which may damage the drive unit. Refer to the manual for wire diameter specifications. Failure to comply may cause accidents!
Before power-on	 Caution	Check that the input voltage level matches the VFD's rated voltage, and verify the correct wiring positions for the input terminals (R, S, T) and output terminals (U, V, W). Additionally, inspect the peripheral circuits connected to the driver for short circuits and ensure all wiring is securely fastened to prevent driver damage. No voltage withstand test is required for any part of the VFD, as it has already been tested at the factory. Otherwise, accidents may occur!
	 Danger	The VFD must have its cover securely closed before power-on, otherwise electric shock may occur! All peripheral accessories must be wired in strict compliance with this manual's instructions and the circuit connection methods provided herein. Failure to do so may cause accidents!
After power-on	 Danger	Do not open the cover after powering on. There is a risk of electric shock! Do not touch any input or output terminals of the VFD. Otherwise, there is a risk of electric shock!
During operation	 Danger	Non-professional personnel should not test signals during operation, as it may cause personal injury or equipment damage! Do not touch the cooling fan or discharge resistor to check temperature, as it may cause burns!
	 Caution	During VFD operation, prevent any objects from entering the equipment to avoid damage. Do not use contactor switching to control the driver's start/stop, as this may cause equipment damage!

Usage Phase	Security Classification	Item
<p>During maintenance</p>	 Danger	<p>Do not perform maintenance or repair on VFDs without professional training, as this may cause personal injury or equipment damage!</p> <p>Do not perform maintenance or repair on the equipment while it is energized, as this may cause electric shock!</p> <p>Ensure the VFD's input power is disconnected for 10 minutes before performing any maintenance or repair on the driver, as residual charges on the capacitors may cause injury!</p> <p>All plug-and-play components must be unplugged when the power is off!</p> <p>After changing the VFD, the parameters must be set and checked.</p>

CONTENT

Preface.....	1
Product Presentation	1
Version Change Log	1
Safety Precautions	2
Chapter 1 Product Information	1
1.1 Naming Rules	1
1.2 Nameplate	1
Chapter 2 Selection List	2
Chapter 3 Product Specifications	3
3.1 Electrical Specifications	3
3.2 Technical Specifications	4
3.3 Personalized Features	5
3.4 Environmental Specification	6
Chapter 4: Optional Accessories	7
4.1 Operation Panel	7
4.2 Cable	9
4.3 External Electrical Components	10
Chapter 5 Mechanical Installation	14
5.1 Machine Dimensions	14
5.2 Installation Requirements	16
5.3 Storage Handling and Unpacking	21
5.4 Install	22
Chapter 6 Electrical Installation	27
6.1 Electrical Wiring Diagram	27
6.2 Main Circuit Terminal Description	29
6.3 Control Circuit Terminal Description	31
Chapter 7 Display and Operation	34
7.1 Display and Operation Overview	34
7.2 Display	36
Chapter 8 Fault Diagnosis and Countermeasures	38
8.1 Fault Alarm and Countermeasures	38
8.2 Common Faults and Their Solutions	42
Appendix A Modbus Communication Protocol	44
1. Agreement Content	44
2. Application Methods	44
3. Bus Architecture	44
4. Agreement Description	44
5. Communication Frame Structure	45
6. Verification Method (CRC Verification Method)	47
7. Address Definition of Communication Parameters	49
Appendix B Functional Parameter Table	53

Chapter 1 Product Information

1.1 Naming Rules

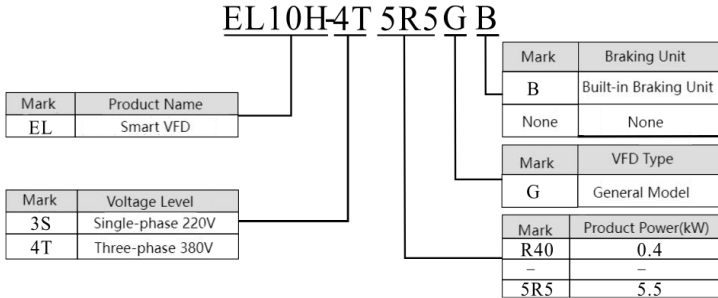

Figure 1-1: Example of Model Names for 3-Phase 5.5kW Products

1.2 Nameplate

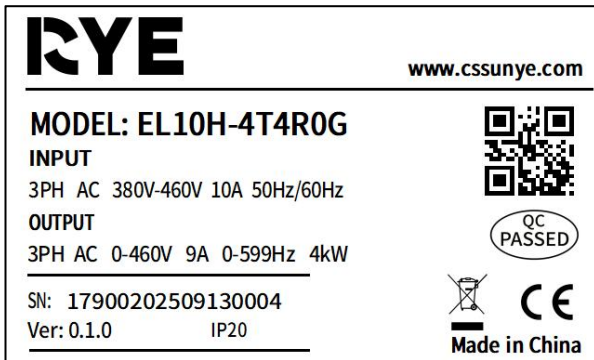

Figure 1-2: Example of 4kW Three-phase Nameplate.

Chapter 2 Selection List

Table 2-1 EL10H Series VFD Models and Basic Specifications (Single-Phase 220V)

Structural Design	VFD Model	Input Voltage (V)	Input Current (A)	Output Current (A)	Applicable Motor (kW)
C0	EL10H-3SR40G	Single-phase 200V ~ 240V Range: ±10%	6.5	2.7	0.4
	EL10H-3SR75G		9.3	4.2	0.75
	EL10H-3S1R5G		15.7	7.5	1.5
C1	EL10H-3S2R2G		24.0	11.0	2.2
C3	EL10H-3S4R0G		32.0	17.0	4.0

Table 2-1 EL10H Series VFD Models and Basic Specifications (Three-Phase 380V)

Structural Design	VFD Model	Input Voltage (V)	Input Current (A)	Output Current (A)	Applicable Motor (kW)
C1	EL10H-4TR75G	Three-phase 380V ~ 460V Range: ±10%	3.2	2.5	0.75
	EL10H-4T1R5G		5.0	4.2	1.5
	EL10H-4T2R2G		7.1	5.5	2.2
C2	EL10H-4T4R0G(B)		10.0	9.0	4.0
	EL10H-4T5R5G(B)		17.0	13.0	5.5
C3	EL10H-4T7R5G(B)		20.5	17.0	7.5
C4	EL10H-4T011GB		26.0	25.0	11.0
	EL10H-4T015GB		35.0	32.0	15.0

Chapter 3 Product Specifications

3.1 Electrical Specifications

3.1.1 220V1φ

Table 3-1: Electrical Specifications of EL10H Single-Phase VFD

Model: EL10H-3S□□□G		R40	R75	1R5	2R2	4R0
Applicable motor power (kW)		0.4	0.75	1.5	2.2	4.0
Applicable motor power (HP)		0.5	1.0	2.0	3.0	5.0
Output	Rated output capacity (kVA)	1	1.6	2.9	4.2	6.5
	Rated output current (A)	2.7	4.2	7.5	11.0	17.0
	Maximum output voltage (V)	Corresponding input voltage				
	Output frequency range (Hz)	0.1Hz~1200Hz				
	Carrier frequency (kHz)	2kHz~6kHz (default 4kHz)				
Input	Input current (A)	6.5	9.3	15.7	24.0	32.0
	Rated voltage, frequency	Single-phase 200V~240V,50/60Hz				
	Allowed input voltage variation range	±10%(180V~264V)				
	Allowable power frequency variation	±5%(47Hz~63Hz)				
Cooling method		Forced air cooling				
Net weight (kg)		0.6	0.6	0.6	0.7	1.4

3.1.2 380V3φ

Table 3-2: Electrical Specifications of EL10H Three-phase VFD

Model: EL10H-4T□□□G (B)		R75	1R5	2R2	4R0(B)	5R5(B)	7R5(B)	011B	015B
Applicable motor power (kW)		0.75	1.5	2.2	4	5.5	7.5	11.0	15.0
Applicable motor power (HP)		1	2	3	5.5	7.5	10	15	15
Output	Rated output capacity (kVA)	2	3.3	4.4	7.4	10.4	14	18	25
	Rated output current (A)	2.5	4.2	5.5	9	13	17.0	25.0	32
	Maximum output voltage (V)	Corresponding input voltage							
	Output frequency range (Hz)	0.1Hz~1200Hz							
	Carrier frequency (kHz)	2kHz~6kHz (default 4kHz)							

Model: EL10H-4T□□G (B)		R75	1R5	2R2	4R0(B)	5R5(B)	7R5(B)	011B	015B
Input	Input current (A)	3.2	4.3	7.1	10	17	20.5	26.0	35
	Rated voltage, frequency	Three-phase power supply, 380V~460V,50/60Hz							
	Allowed input voltage variation range	±10%(342V~506V)							
	Allowable power frequency variation	±5%(47Hz~63Hz)							
Cooling method		Forced air cooling							
Net weight (kg)		0.7	0.7	0.7	1.2	1.2	1.4	2.45	2.45

3.2 Technical Specifications

Table 3-3: Technical Specifications of EL10H VFD

Project		Specifications	
Control characteristic	Control method	V/F control, vector control (Supported by 4.0kW and above VFDs)	
	Output frequency resolution	0.01Hz	
	Overload capacity	Operating at 150% of the rated output current for 60 seconds, and at 180% for 3 seconds.	
	Frequency setting prohibition	4 points within 0.1~1200.0Hz	
	Acceleration and deceleration time	0.1 to 600 seconds (four acceleration/deceleration stages can be set independently)	
	Stall prevention	Set the current at 20% to 200% of the driver's rated current based on the motor's load characteristics.	
	DC injection braking	Braking current: 0~100% rated current, Braking time: 0~100s	
	V/F curve	General V/F curve setting, 1.5th power curve setting, 2nd power curve setting	
Revolve characteristic	Frequency setting signal	Panel operations	Panel VR settings
		External signal	External terminals: UP/DOWN frequency, point operation AVI/ACI: 0~+10VDC/0~20mA Serial communication port: Standard models support RS485
	Revolve set signal	Panel operations	Set by RUN and STOP keys
		External signal	DI1, DI2, DI3, DI4 2-wire/3-wire control, Jog operation, Serial communication (RS485)
	Input terminal function	16-speed mode (including main speed) with default speed switching, acceleration/deceleration prohibition command, 4-speed acceleration/deceleration switching, external counting, fault reset, increment/decrement terminal frequency setting, and jogging operation.	

Project		Specifications
	Output terminal function	Running indicator, frequency arrival indicator, zero speed indicator, counter arrival indicator, fault indicator, overheating warning, emergency stop, etc.
Human - machine interface	Communication	EL10H supports RS485 communication (Cannot be used simultaneously with an external keypad)
	Analogue input	1-channel AI
	Analog output	1-channel AO (Standard for 7.5kW and above; Optional for 5.5kW and below)
	Digital quantity input	4-channel DI
	Digital quantity output	1-channel Normally Open (NO) relay output, 1-channel Normally Closed (NC) relay output (7.5kW and above)
	Digital control panel	Includes 6 function keys, 4-digit 7-segment LED display (5-digit 7-segment LED display standard for 7.5kW and above), and 4 LED status indicators. Functions include frequency setting, real-time output frequency/current display, parameter browsing/editing/locking, fault display, and Run/Stop/Reset commands
Protection function		Undervoltage, overvoltage, overcurrent, IGBT overheating, VFD overload, motor overload, detected circuit fault, PID disconnection, parameter read error, incorrect parameter password, communication error, communication timeout, excessive slip, output phase loss, external terminal fault, external interrupt operation, etc.

3.3 Personalized Features

Table 3-4: Customized Features of EL10H VFD

Project	Specifications
Acceleration/Deceleration curve	Straight line, S-curve (starting arcs can be set separately)
Built-in PID	Built-in PID for process control in specific applications
Operation command channel	Three channels: control panel, external terminals, and communication settings (switchable via parameters)
Frequency hopping function	Skip some frequency bands and avoid resonance points.
Dynamic braking	Reduces bus voltage spikes through energy dissipation
Multi-stage speed running	Supports 16-speed switching via external terminals
Automatic voltage regulation	Automatically maintains constant output voltage when grid voltage fluctuates
Overvoltage and overcurrent stall prevention	Automatically limits current and voltage during operation to prevent frequent overcurrent and overvoltage tripping
Stops non-stop.	When there is an instantaneous power outage, the voltage drop is compensated through certain means to maintain the normal operation of the VFD for a short period of time

3.4 Environmental Specification

Table 3-5: Environmental Specifications for EL10H VFD

Project	Specifications
Usage location	For altitudes below 1000m, use indoors (free of corrosive gases, liquids, and dust). For altitudes above 1000m, use with reduced capacity.
Ambient temperature	-10°C~+40°C (except for naturally cooled models, when installed side by side in close proximity, the maximum operating temperature is 40°C. If exceeding 40°C, the equipment must be used at reduced capacity, with a maximum operating temperature of 50°C)
Storage temperature	-20°C~+60°C
Humidity	Below 95%RH (no condensation)
Vibrate	Complies with IEC60068-2-6
Protection level	IP20
Degree of pollution	2
Cooling method	Forced air cooling

Chapter 4: Optional Accessories

Table 4-1: EL10H VFD Accessories

Name	Internal Model	Function	Remarks
LED external panel	KPL-LED1	LED control panel for parameter display and settings	/
	CM800-JP-09-04	LED keyboard mounting base	/
	Ethernet cable 1	Extension cable for the control panel, with RJ45 terminal	/
DIN guide rail installation	Not have	EL10H guide rail installation accessories	Please refer to Figure 2-8, the guide rail size diagram, for your selection.
Cable/Port	Not have	The drive is connected to the power grid, motor, or other peripheral electrical equipment.	Please refer to the recommendations and requirements in 4-2 for your own selection.
External electrical components	Not have	Peripheral electrical equipment for the drive	Please refer to the recommendations and requirements in Section 4-3 for your own selection.

1*line length is optional. Please consult the business department for purchase.

4.1 Operation Panel

Table 4-2: EL10H VFD Control Panel

Model	Description	Surface
KPL-LED1	LED control panel for parameter display and settings.	

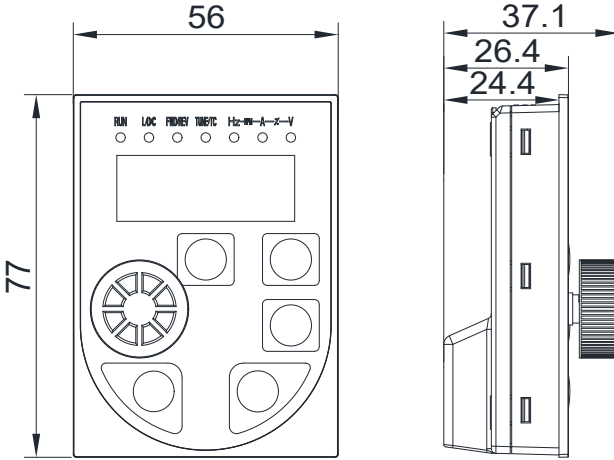

Figure 4-1: Operation Panel Size Diagram (unit: mm)

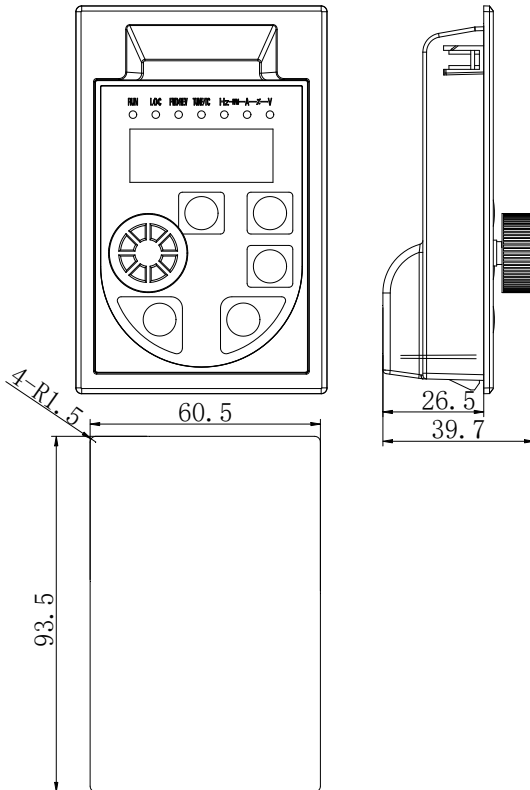

Figure 4-2: Bracket Dimensions and Recommended Hole Sizes (unit: mm)

4.2 Cable

4.2.1 Main Circuit Cables

For power cable size selection, please comply with the regulations of respective countries or regions. IEC cable selection is based on:

- Complies with EN60204-1 and IEC60364-5-52 standards.
- PVC copper conductor cable is used.
- Ambient temperature: 40°C, cable surface temperature: 70°C. (Note: Contact the manufacturer if ambient temperature exceeds 40°C.)
- Symmetrical cable with copper mesh shielding.

If the recommended cable specifications for peripheral devices or optional accessories exceed the product's applicable cable range, please contact our company. To comply with EMC standards, ensure the use of shielded cables. Shielded cables are available in two types: three-phase and four-phase, as shown in the figure below. For three-phase shielded cables, if the shielding layer's conductivity fails to meet requirements, an additional independent PE wire should be added. Alternatively, a four-phase shielded cable may be used with one PE wire. To effectively suppress RF interference, the shielding layer should consist of coaxial copper braided tape. To enhance shielding effectiveness and conductivity, the braiding density of the shielding layer should exceed 90%.

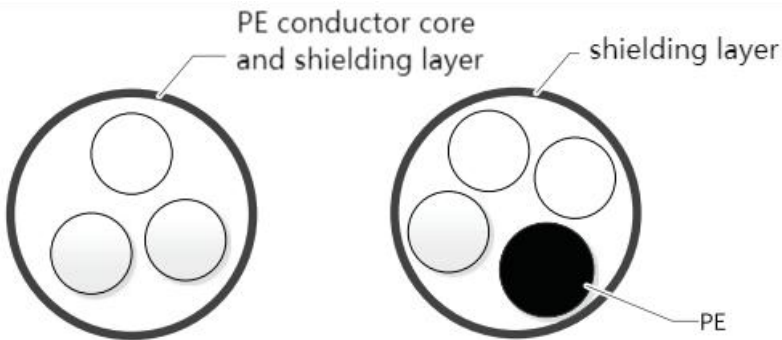

Figure 4-3: Recommended Power Cable Type

4.2.2 Control Loop Cables

To ensure IO signal lines are immune to external strong interference noise, shielded cables with shielding layers are recommended. Signal shielding brackets should be installed at both ends of the shielding layer to achieve 360° reliable connection with the equipment. Separate shielded cables should be used for different analog signals, while shielded twisted-pair cables are recommended for digital signal lines.

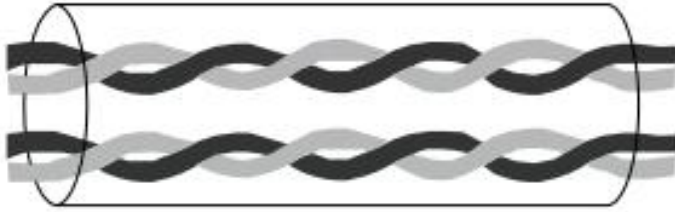

Figure 4-4: Schematic Diagram of Shielded Twisted Pair

Refer to the table below for the cross-sectional area of main and control circuit cables and recommended terminal types.

Table 4-3: Recommended Wire Diameter and Terminal Lug Type For EL10H VFD

Structure Number	VFD Model	Recommended Wire and Terminals for RST/UVW/GND		Control Loop Wire (mm ²)	Control Loop Wire Lug Model
		Lead (mm ²)	Wire Rod Model		
C0	EL10H-3SR40G	1	E1010	0.5	E0510
	EL10H-3SR75G	2.5	E2510	0.5	E0510
	EL10H-3S1R5G	2.5	E2510	0.5	E0510
C1	EL10H-3S2R2G	4	E4012	0.5	E0510
	EL10H-4TR75G	0.75	E7512	0.5	E0510
	EL10H-4T1R5G	0.75	E7512	0.5	E0510
	EL10H-4T2R2G	1	E1012	0.5	E0510
C2	EL10H-4T4R0G(B)	2.5	E2512	0.5	E0510
	EL10H-4T5R5G(B)	2.5	E2512	0.5	E0510
C3	EL10H-3S4R0G	6	E6018	0.5	E0510
	EL10H-4T7R5G(B)	6	E6018	0.5	E0510
C4	EL10H-4T011GB	10	E10-18	0.5	E0510
	EL10H-4T015GB	10	E10-18	0.5	E0510

4.3 External Electrical Components

4.3.1 Circuit Breaker and Fuse

- (1) The rated current of the circuit breaker must be between 2 to 4 times the rated input current of the VFD.
- (2) Fuses with specifications smaller than those listed in the table below are permitted.

Table 4-4: Recommended Circuit Breaker and Fuse Specifications for EL10H VFD

Structure Number	VFD Model	Rated Input Current (A)	Recommended Semiconductor Fuse Specification (A)	Recommended Circuit Breaker Specifications (A)
C0	EL10H-3SR40G	6.5	15	15
	EL10H-3SR75G	9.3	20	20
	EL10H-3S1R5G	15.7	40	30
C1	EL10H-3S2R2G	24	50	50
	EL10H-4TR75G	3.2	10	10
	EL10H-4T1R5G	4.3	10	10
	EL10H-4T2R2G	7.1	15	15
C2	EL10H-4T4R0G(B)	10	20	20
	EL10H-4T5R5G(B)	17	40	40
C3	EL10H-3S4R0G	32	50	50
	EL10H-4T7R5G(B)	20.5	50	50
C4	EL10H-4T011GB	26	60	60
	EL10H-4T015GB	35	60	60

4.3.2 EMC Filter

To ensure compliance with ENIEC61800-3 standards, this product requires an external EMC filter. Customers should purchase one based on the rated input current. For brand and model recommendations, please contact our after-sales service.

Table 4-5: Recommended EMC Filter Specifications for EL10H VFD

Structure Number	VFD Model	Rated Input Current (A)	Recommended EMC Filter Specifications (A)
C0	EL10H-3SR40G	6.5	10
	EL10H-3SR75G	9.3	10
	EL10H-3S1R5G	15.7	20
C1	EL10H-3S2R2G	24	30
	EL10H-4TR75G	3.2	5
	EL10H-4T1R5G	4.3	5
	EL10H-4T2R2G	7.1	10
C2	EL10H-4T4R0G(B)	10	20
	EL10H-4T5R5G(B)	17	20
C3	EL10H-3S4R0G	32	36
	EL10H-4T7R5G(B)	20.5	30
C4	EL10H-4T011GB	26	30
	EL10H-4T015GB	35	40

4.3.3 Input Reactor

- (1) Improve the input side power factor;
- (2) Eliminate the high-order harmonics on the input side to prevent damage to other equipment caused by voltage waveform distortion.
- (3) Eliminate the input current unbalance caused by the phase unbalance of power supply;
- (4) When deploying small-capacity VFDs in large-capacity power grids (typically with a 10:1 ratio), the low grid impedance may cause thermal stress and reduced lifespan in rectifier bridges and bus capacitors. If all four specified requirements are met, input reactors can be installed. The recommended specifications are as follows:

Table 4-6: Recommended Input Reactor Specifications for EL10H VFD

Structure Number	Power Grid	VFD Model	Recommended Input Reactor Rated Current (A)	Maximum Continuous Input Current (A)	Recommended Input Reactor Inductance (mH): 3–5% Impedance
C0	1-phase 220V	EL10H-3SR40G	6.5	9.75	3
		EL10H-3SR75G	9.3	13.95	1.5
		EL10H-3S1R5G	15.7	23.55	1.25
C1	2-phase 380V	EL10H-3S2R2G	24	36	0.8
		EL10H-4TR75G	3.2	4.8	10
		EL10H-4T1R5G	4.3	6.45	9
C2		EL10H-4T2R2G	7.1	10.65	6
		EL10H-4T4R0G(B)	10	15	4
C3	1-phase 220V	EL10H-4T5R5G(B)	17	25.5	2
		EL10H-3S4R0G	32	48	0.2
C4	3-phase 380V	EL10H-4T7R5G(B)	20.5	30.75	0.7
		EL10H-4T011GB	26	39	0.47
		EL10H-4T015GB	35	50	0.35

4.3.4 Output Reactor

Installing an output reactor on the driver's output side reduces excessive dV/dt, thereby lowering voltage stress on motor windings, protecting them, reducing motor temperature, and extending service life. The decision to install an output reactor should be based on specific conditions. The transmission line between the VFD and motor should not be excessively long, as longer cables increase distributed capacitance, which can generate higher-order harmonic currents. When the application environment requires high harmonic performance from the power grid, a distribution reactor may be selected; otherwise, it is unnecessary.

Table 4-7: Recommended Specifications for Output Reactors of EL10H VFD

Structure Number	VFD Model	Recommended Output Reactor Rated Current (A)	Maximum Continuous Output Current (A)	Recommended Output Reactor Inductance (mH) Impedance: 3–5%
C0	EL10H-3SR40G	2.7	4.05	12
	EL10H-3SR75G	4.2	6.3	7.5
	EL10H-3S1R5G	7.5	11.25	2.5
C1	EL10H-3S2R2G	11	16.5	2
	EL10H-4TR75G	2.5	3.75	25
	EL10H-4T1R5G	4.2	6.3	8
	EL10H-4T2R2G	5.5	8.25	7
C2	EL10H-4T4R0G(B)	9	13.5	4
	EL10H-4T5R5G(B)	13	19.5	2
C3	EL10H-3S4R0G	17	25.5	0.2
	EL10H-4T7R5G(B)	17	25.5	0.35
C4	EL10H-4T011GB	25	37.5	0.23
	EL10H-4T015GB	32	48	0.18

4.3.5 Magnetic Ring and Magnetic Buckle

The magnetic ring can be installed on either the input or output side of the drive. Place it as close to the drive as possible. Installing the magnetic ring on the input side improves the drive's EMI performance relative to the power grid. Installing it on the output side primarily reduces external interference from the drive while lowering bearing current.

For leakage current and signal line interference in some applications, magnetic ring or magnetic buckle can be used to suppress them.

- Amorphous magnetic ring: It has high permeability below 1MHz, which is very effective in driving interference, but the cost is slightly higher.
- Ferrite magnetic latch: It has good characteristics in the frequency band above 1MHz, and it has good effect of suppressing interference for various signal lines for low-power driver, and it has low cost.

Please determine whether to install magnetic rings or magnetic clips based on the actual on-site debugging conditions.

Chapter 5 Mechanical Installation

5.1 Machine Dimensions

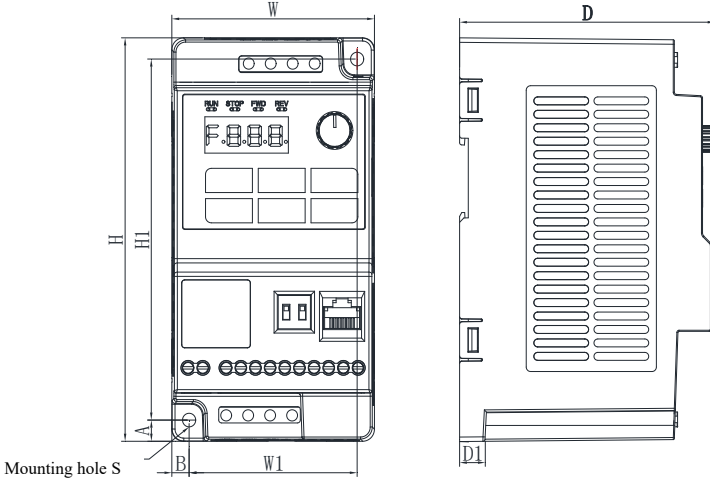

Figure 5-1: Schematic Diagram of C0 External and Installation Dimensions

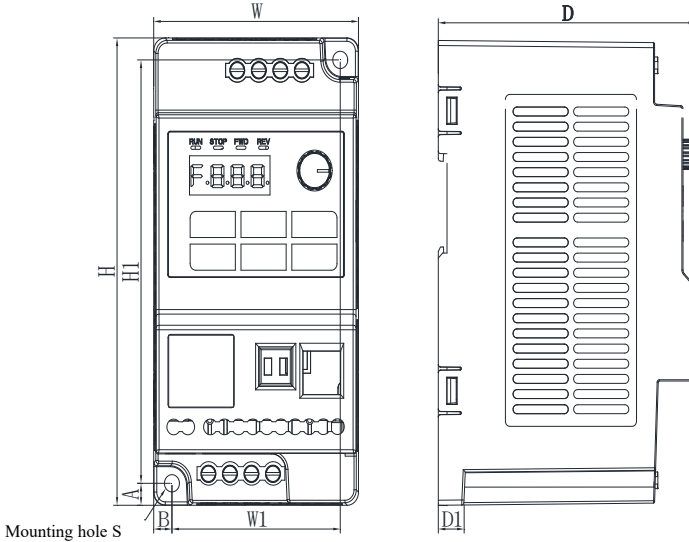

Figure 5-2: Schematic Diagram of C1 External and Installation Dimensions

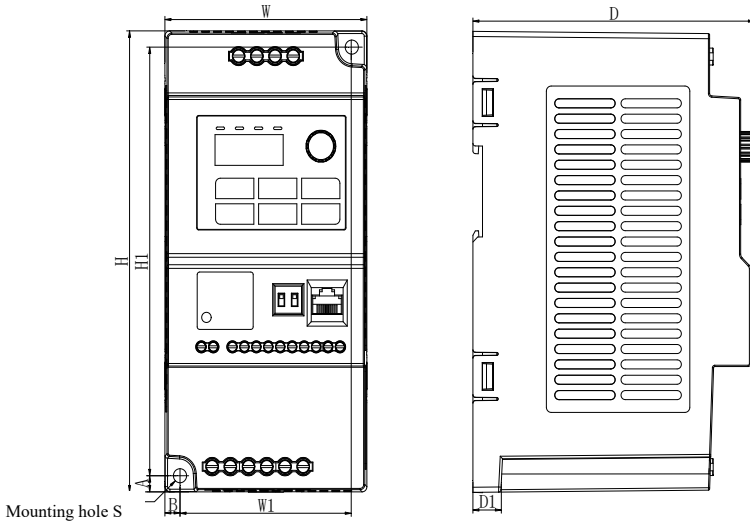

Figure 5-3: Schematic Diagram of C2 External and Installation Dimensions

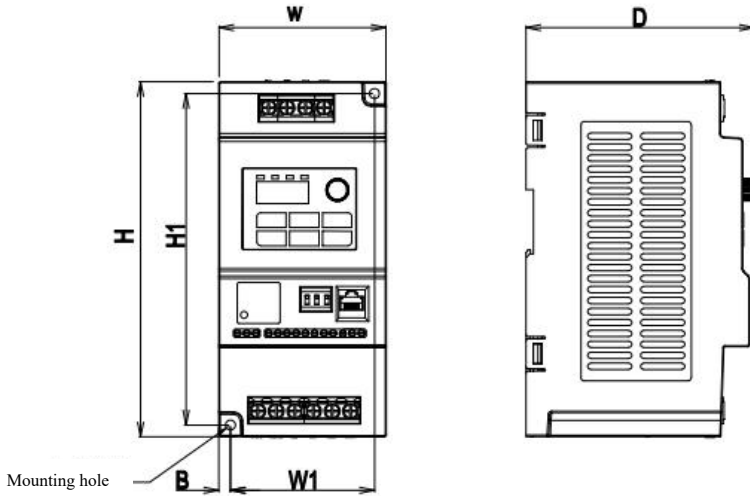

Figure 5-4: Schematic Diagram of C3 External and Installation Dimensions

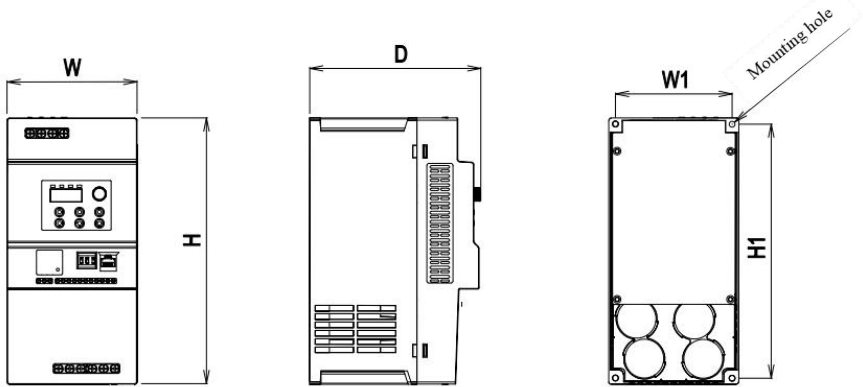

Figure 5-5: Schematic Diagram of C4 External and Installation Dimensions

Table 5-1: EL10H-C0~C4 External Shape and Mounting Hole Dimensions (unit: mm)

Structure Number	W	W1	H	H1	D	D1	A	B	Installation Hole Diameter S (mm)	Wet Weight (Kg)
C0	69.0	57.5	133.0	119.5	104.0	11.5	7.0	6.0	Φ4.5	0.6
C1	73.0	60.0	143.0	130.0	105.0	11.5	6.8	6.5	Φ5.5	0.7
C2	84.5	72.0	180.0	167.5	117.5	12.0	6.3	6.3	Φ5.5	1.2
C3	91.5	79	194.5	184.5	125	13.0	6.5	6.5	Φ5.5	1.4
C4	117	105	239.5	229	154	10.0	5.5	6.0	Φ5.5	2.45

5.2 Installation Requirements

5.2.1 Installation Environment

- (1) Ambient temperature: -10 °C to +40 °C (when installed side-by-side in close proximity, the maximum operating temperature is 40°C. Operations exceeding 40°C require reduced capacity, with a maximum allowable temperature of 50°C).
- (2) Mount the VFD on the surface of a flame-retardant material, ensuring sufficient cooling space around it, and secure it vertically to the mounting bracket with screws.
- (3) Install in a location with minimal vibration ($\leq 0.6g$), and keep away from equipment like stamping machines.
- (4) Avoid installation in areas with direct sunlight, humidity, or dripping water.
- (5) Avoid installation in areas with corrosive, flammable, or explosive gases in the air.
- (6) Avoid installation in areas with oily contamination, high dust levels, or metal dust accumulation.

5.2.2 Installation Space

Depending on the power rating of the VFD, the required installation space and spacing around the device may vary slightly.

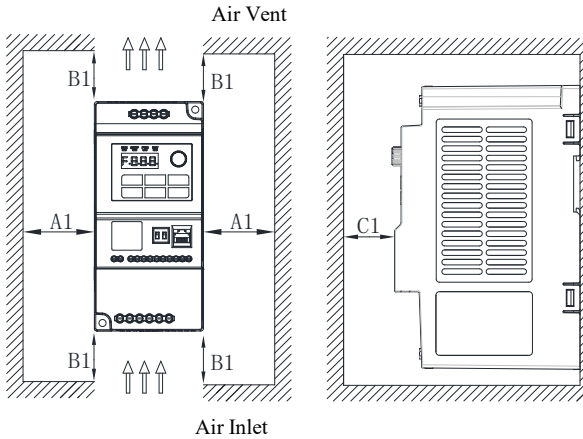

Figure 5-4: Installation Diagrams for Models C0 ~ C4 (Single Equipment Installation)

Table 5-2: Space Requirements for 0.4~15kW Installation (Single Equipment Installation)

Storage Space Requirements			
Power level	Size requirements (unit: mm)		
0.4kW	A1≥20	B1≥80	C1≥80
0.75kW	A1≥20	B1≥80	C1≥80
1.5kW	A1≥20	B1≥80	C1≥80
2.2kW	A1≥20	B1≥80	C1≥80
4.0kW	A1≥20	B1≥80	C1≥80
5.5kW	A1≥20	B1≥80	C1≥80
7.5kW	A1≥20	B1≥80	C1≥80
11kW	A1≥20	B1≥80	C1≥80
15kW	A1≥20	B1≥80	C1≥80

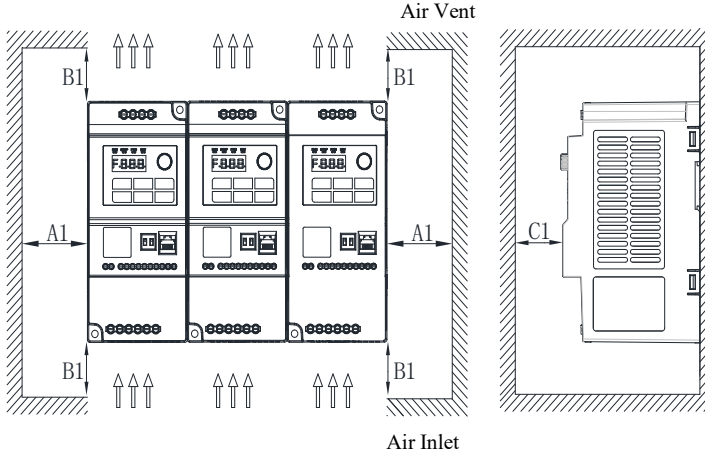

Figure 5-5: Installation Diagrams for Models C0 ~ C4 Models (Side-by-Side Installation)

Table 5-3: Space Requirements for 0.4~15kW Installation(Side-by-Side Installation)

Storage Space Requirements			
Power level	Size requirements (unit: mm)		
0.4kW	A1≥20	B1≥100	C1≥80
0.75kW	A1≥20	B1≥100	C1≥80
1.5kW	A1≥20	B1≥100	C1≥80
2.2kW	A1≥20	B1≥100	C1≥80
4.0kW	A1≥20	B1≥120	C1≥80
5.5kW	A1≥20	B1≥120	C1≥80
7.5kW	A1≥20	B1≥120	C1≥80
11kW	A1≥20	B1≥120	C1≥80
15kW	A1≥20	B1≥120	C1≥80

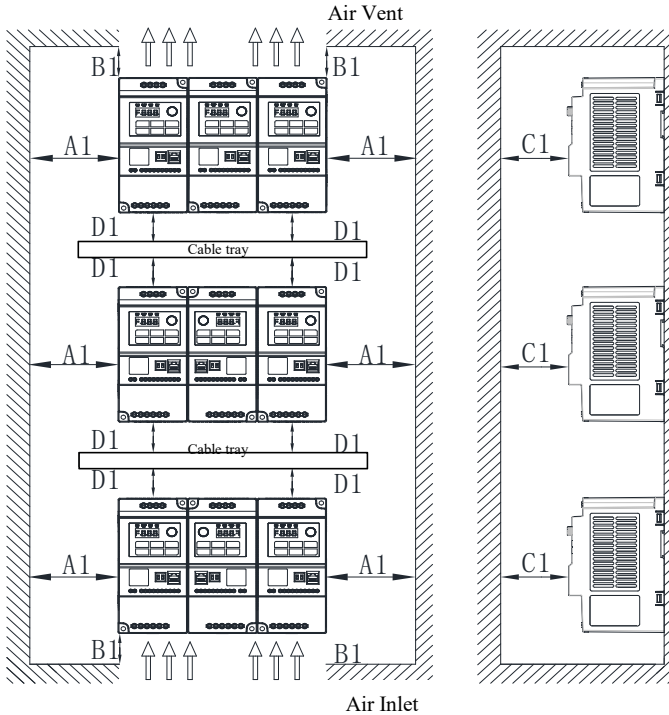

Figure 5-6: Installation Diagrams for Models C0 ~ C4 Models (Top and Bottom Parallel Installation)

Table 5-4: Space Requirements for 0.4~15kW Installation (Top and Bottom Parallel Installation)

Storage Space Requirements				
Power level	Size requirements (unit: mm)			
0.4kW	A1≥20	B1≥100	C1≥80	D1≥80
0.75kW	A1≥20	B1≥100	C1≥80	D1≥80
1.5kW	A1≥20	B1≥100	C1≥80	D1≥80
2.2kW	A1≥20	B1≥100	C1≥80	D1≥80
4.0kW	A1≥20	B1≥120	C1≥80	D1≥80
5.5kW	A1≥20	B1≥120	C1≥80	D1≥80
7.5kW	A1≥20	B1≥120	C1≥80	D1≥80
11kW	A1≥20	B1≥120	C1≥80	D1≥80
15kW	A1≥20	B1≥120	C1≥80	D1≥80

5.2.3 Please Pay Attention to Machine Installation

Install the VFD vertically to facilitate upward heat dissipation, but avoid upside-down placement. When multiple VFDs are installed in the cabinet, arrange them side by side with the upper parts aligned. For

installations requiring vertical alignment, refer to the schematic installation in Figure 5-6 to prevent overheating of upper units caused by heat from lower units.

The installation space should comply with Tables 5-2, 5-3, and 5-4 to ensure adequate cooling for the VFD, while also accounting for the heat dissipation of other cabinet components during layout.

Note:

When installing this series of VFDs, ensure vertical orientation. Do not install them in other positions such as horizontal, side, or upside-down.

5.2.4 Replacement Tool

Table 5-5: Mechanical Installation Tools Table

Tool Name	Explain
Electric drill and drill bit	Drill the installation hole on the installation surface when the equipment is installed by machine.
Cross and straight screwdriver	Used to tighten or loosen screws during VFD installation.
Band tape	It is used to measure the installation size and calibration of the VFD.
Gloves	Wear gloves during VFD installation to prevent static electricity.
Install the guide rail (see Figure 5-7 for optional accessories)	When installing the VFD in the cabinet, secure it using the mounting rails.
Nut bolt	The VFD is fixed to the installation surface.

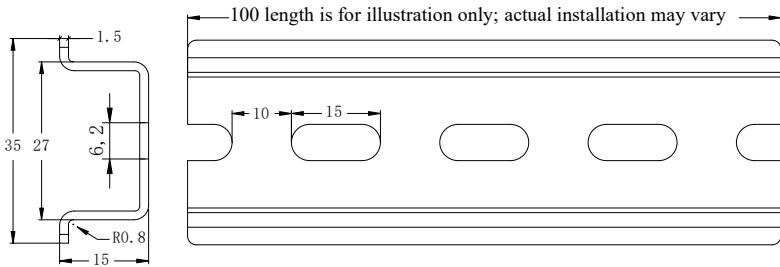

Figure 5-7: Schematic Diagram of Guide Rail Dimensions (unit: mm)

The required accessories and quantities for mechanical installation are listed in the table below:

Table 5-6: List of Options

Installation Method	Screw Specifications	Quantity	Explain
Wall-mounted installation	Purchase based on the installation hole size and usage scenario	2	For mounting this device on the wall
Installation inside cabinet	Refer to Figure 5-7 for rail dimensions. Customers are required to purchase or customize the rails themselves.	1	For securing this device to the guide rail bracket

Wiring tool

When wiring the main circuit terminals, consider their size and dimensions, select appropriate tools for wiring, and secure them firmly. See the table below for detailed requirements of wiring and installation tools.

Table 5-7: Main Circuit Terminal Wiring Installation Tool Requirements

Structure Number	Required Tools
C0-C2	One-wire screwdriver, cross screwdriver, wire stripper, wire cutter

5.3 Storage Handling and Unpacking

5.3.1 Storage

When storing for extended periods, maintain the integrity of the product packaging or use protective measures to shield the equipment from environmental influences.

- (1) Keep the VFD protected from harsh environments, including dust, direct sunlight, corrosive substances, flammable gases, oils, moisture, and vibrations.
- (2) The storage temperature of this product should be maintained between -20°C and $+60^{\circ}\text{C}$, and the ambient temperature should not undergo drastic changes.
- (3) For VFD products stored for extended periods, ensure a power-on test within 6 months with at least 5 hours of operation to prevent electrolytic capacitor degradation. The input voltage must be gradually increased to the rated level using a voltage regulator. For any inquiries, please contact the manufacturer's technical support.

5.3.2 Handling Before Unpacking

Transportation precautions:

The EL10H series features compact and lightweight designs, making them easy to handle manually. Handle with care when lifting or placing.

5.3.3 Packaging Confirmation

Upon receiving the goods, verify that the delivery note matches the physical items, the packaging is original factory packaging, and there are no damage or other issues. If any missing or damaged items are found, contact the shipping company immediately for resolution. Do not connect the equipment if the product is damaged. Wait for professional personnel to confirm the electrical safety of the product before operating it. For assistance, please contact the manufacturer's technical support.

5.3.4 Packing List

The product is packaged in cardboard boxes, with the detailed packing list as follows:

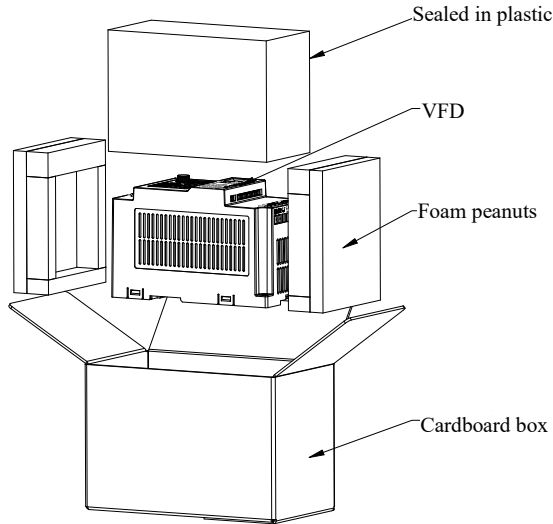

Figure 5-8: Packing List

5.3.5 Unpack

The package removal steps are as follows:

- (1) Lift the lid of the box.
- (2) Remove all the filling material.
- (3) Remove this device.
- (4) Cut the plastic film of the device.
- (5) Ensure the product shows no signs of damage.
- (6) Dispose or recycle packaging in accordance with local regulations.

5.3.6 Explain

For C0~C2 models, the equipment is compact and lightweight, allowing manual handling.

For C0~C2 models, both wall-mounted and embedded installation options are supported.

5.4 Install

Pre-installation Notes

Before installing the VFD in the control cabinet, check the cabinet design to ensure sufficient installation and cooling space. During installation, ensure the installation position has adequate strength to support the equipment weight.

When installing, cover the top of the device with cloth or paper to prevent metal shavings, oil, or water from entering during drilling. If foreign objects enter the device, it may cause malfunctions. After completing the installation, remove the cover to ensure proper heat dissipation.

The installation area must provide adequate cooling space for the equipment, with consideration for heat dissipation of other cabinet components. For details, refer to the “Single Equipment Installation”, “Parallel Installation”, and “Vertical Parallel Installation” sections in the “5.2.2 Installation Space” section.

When mounting brackets are required, they must be made of flame-retardant materials.

For applications involving metal dust, it is recommended to use enclosed cabinets to isolate the equipment from metal dust. Ensure the fully sealed cabinet has sufficient cooling space.

Lock all screws to the specified torque to prevent fire or electric shock hazards.

Do not place flammable or explosive items near the device.

5.4.1 Wall Mounting

Refer to Section 5.1 for the position and diameter of the wall-mounted mounting holes.

Installation

Use a crosshead screwdriver to tighten the two screws located at the upper right and lower right corners of the VFD (recommended screws: M4 and M5 crosshead screws; length specifications are customizable based on actual installation conditions).

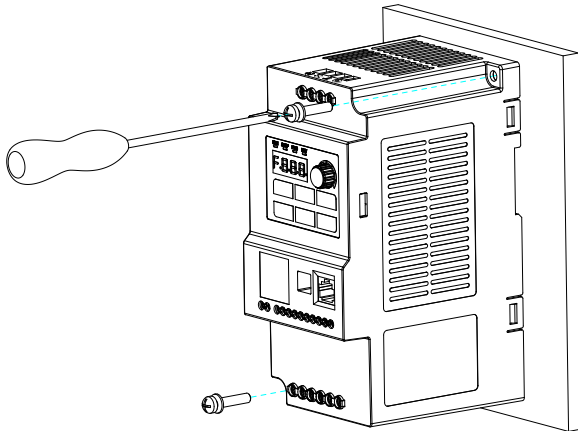

Figure 5-9: Wall-mounted Installation

Explain:

When installing a VFD with wall-mounted mounting, both the upper-right and lower-left screws must be tightened simultaneously. Only securing one screw is strictly prohibited, as prolonged operation may cause the fixed component to detach or sustain damage due to uneven stress distribution.

When disassembling, use a crosshead screwdriver to remove the two mounting screws on the VFD, then take it off.

5.4.2 Guide Rail Installation Method

For VFD installation using the rail mounting method, please purchase DIN rail mounting accessories (optional). Refer to “Table 5-5: Mechanical Installation Tools Table” for details.

Use a single-letter screwdriver to gently pry the guide rail clip out a little distance, as shown in the figure below.

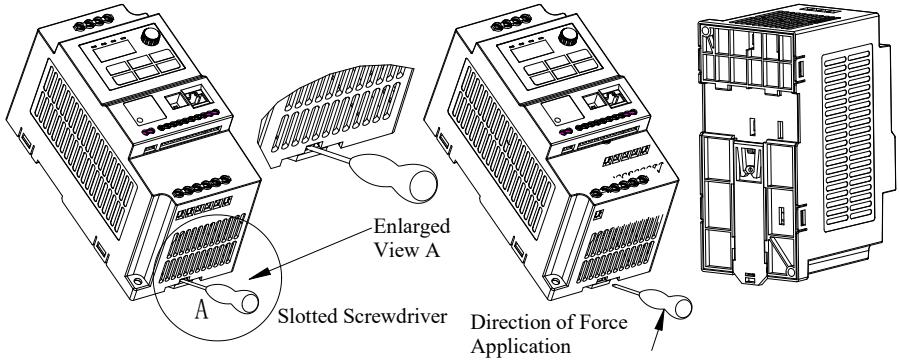

Figure 5-10: Schematic Diagram of Guide Rail Installation 1

Scenario 1

If the guide rail has not yet been installed in the cabinet, first position the entire unit in the direction shown in Figure 5-11 Guide Rail Installation Schematic 2, then secure the snap-fit fastener in place. Next, follow the arrow instructions to fasten the product onto the guide rail as shown in Figure 5-12 Guide Rail Installation Schematic 3. Finally, press the guide rail snap-fit fastener upward to the bottom, locking it firmly to complete the installation.

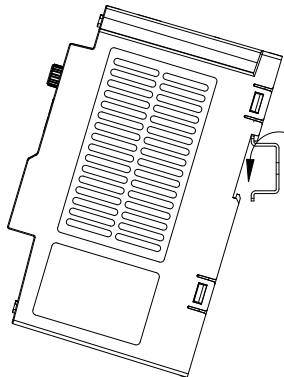

Figure 5-11: Schematic Diagram of Guide Rail Installation 2

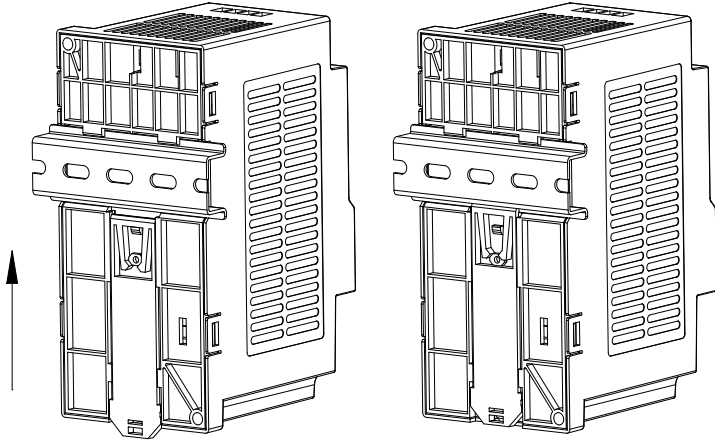
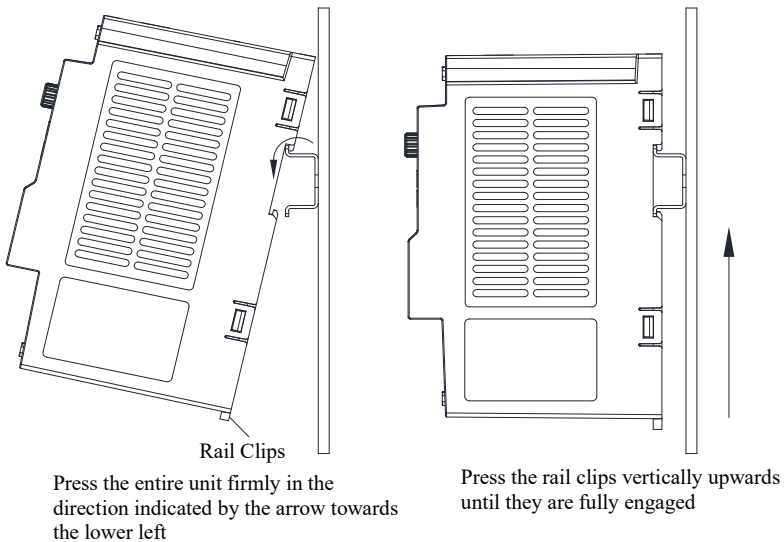

Figure 5-12: Schematic Diagram of Guide Rail Installation 3

Scenario 2

If the guide rail is already installed in the cabinet, first secure the entire unit as shown in Figure 5-13 (Guide Rail Installation Schematic 4). Then, using your hands, press firmly downward diagonally along the arrow direction (left panel of Figure 5-13) to the unit's base. This will engage the guide rail into the unit's latch. Once locked, fully press the latch upward to secure the guide rail, completing the installation.



Press the entire unit firmly in the direction indicated by the arrow towards the lower left

Press the rail clips vertically upwards until they are fully engaged

Figure 5-13: Schematic Diagram of Guide Rail Installation 4

Dismantle

When wiring the control circuit, ensure the machine is powered off for over 10 minutes.

Use a single-letter screwdriver to gently pry the guide rail clip slightly outward, releasing it from the rail. Then pull the entire unit diagonally upward and outward to detach it from the guide rail.

If you choose rail installation, we recommend using Scenario 1 installation method.

Chapter 6 Electrical Installation

6.1 Electrical Wiring Diagram

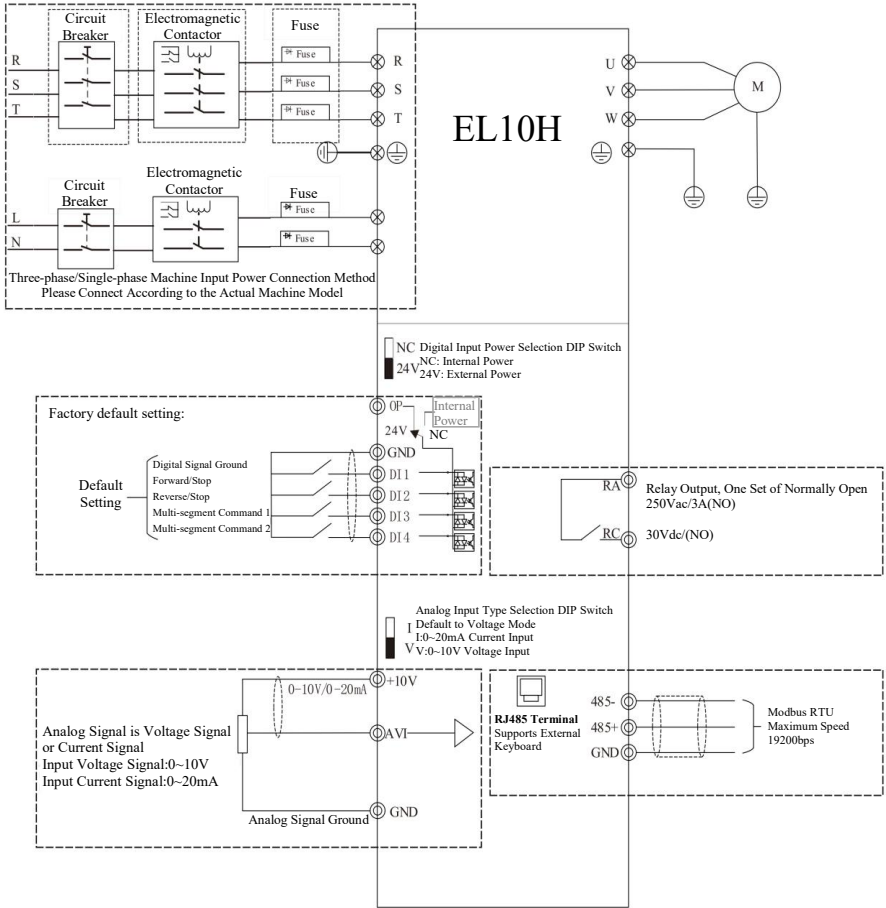

Figure 6-1: Wiring Diagram of 3-Phase/1-Phase Power Input Terminals (5.5kW and below)

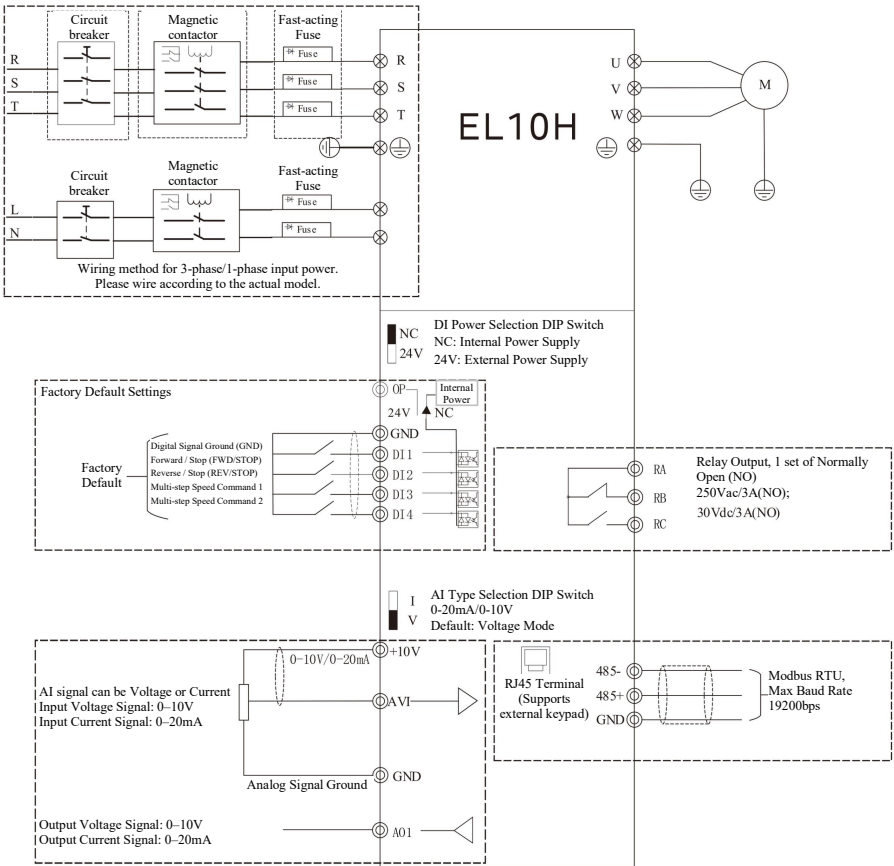
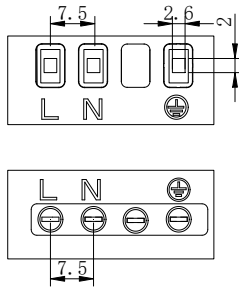

Figure 6-2: Wiring Diagram of 3-Phase/1-Phase Power Input Terminals (7.5kW and above)

6.2 Main Circuit Terminal Description

6.2.1 Main Circuit Terminal



Input Terminals

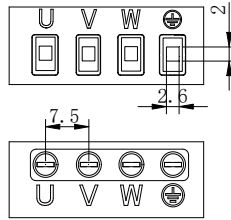

Output Terminals

C0

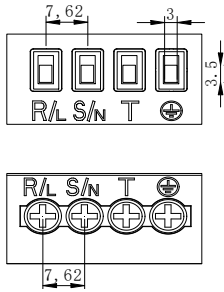

Input Terminals

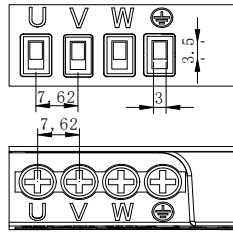

Output Terminals

C1

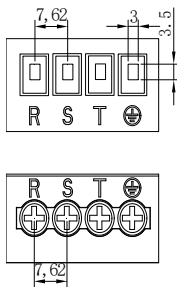

Input Terminals

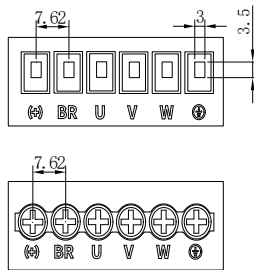

Output Terminals

C2

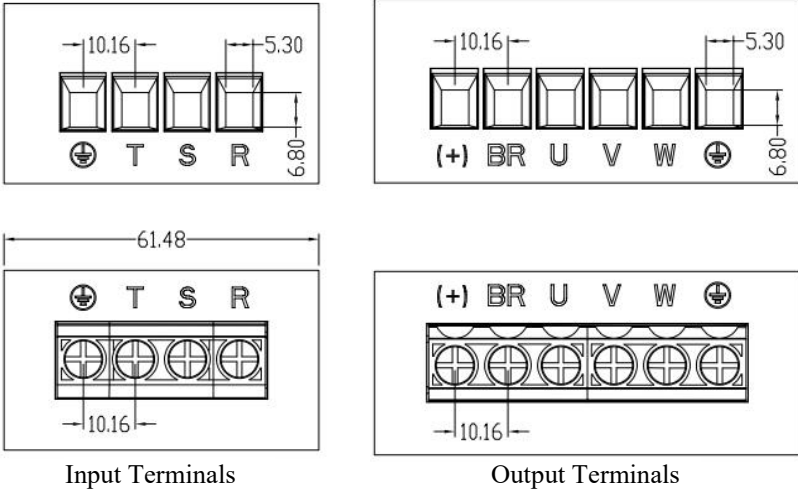

C3/C4

Figure 6-2: Configuration of Main Circuit Terminals for EL10H VFD

Table 6-1: Main Circuit Terminal Labeling Description

Terminal Marking	Name	Explain
R,S,T	Three-phase power supply input terminal	AC three-phase power input connection point
R/L,S/N	C1 frame three-phase/single-phase power supply compatible input terminal	AC input three-phase/one-phase power connection point
(+),BR	Braking resistor terminal	The 4.0kW/5.5kW brake-equipped unit model is reserved but not currently supported.
U,V,W	VFD output terminal	Three-phase motor connection
	Earth terminal	Landing

6.2.2 Distribution Wiring Considerations

The output-side voltage (U), voltage (V), and current (W) of the VFD

Capacitors or surge absorbers must not be connected to the VFD output side, as this may cause frequent protection trips or even damage to the VFD.

When the motor cable is excessively long, electrical resonance may occur due to distributed capacitance, potentially causing insulation  failure or excessive leakage current, which could trigger overcurrent protection grounding in the VFD.

The terminals must be reliably grounded, otherwise the equipment may malfunction or even be damaged.

Do not share the grounding  terminal with the power neutral N terminal.

6.3 Control Circuit Terminal Description

6.3.1 Control Loop Terminal

The terminal layout diagram of the control circuit is shown below:

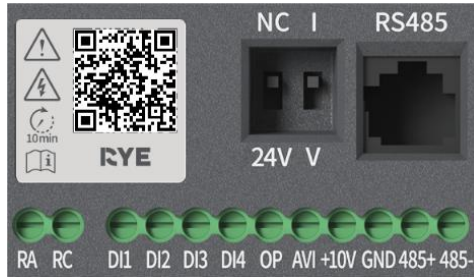

Figure 6-3: Control Circuit Terminal Layout Diagram (EL10H)

6.3.2 Terminal/Dial Function Description

Table 6-2: EL10H VFD Control Terminal/Dial Function Description

Classification	Terminal/Dial Code Symbol	Terminal/Dial Code Name	Function Declaration
Power input	OP	Terminal for switching between internal and external power supply via NC/24V DIP switch	When the toggle switch is set to NC, the OP terminal requires no wiring, and the DI is powered by the internal power supply. When the DIP switch is set to 24V, the OP terminal must be connected to an external 24V power supply to power the input DI.
Power supply selection	NC/24V	Internal and external power source selection	
Analog input	AVI	Read analogue input	Input range: DC0~10V/0~20mA, configurable by the customer. Input impedance: 57kΩ±5% for voltage input, 500Ω for current input.
Analog input power supply	+10V	Analog input power supply	Internal precision power supply for analog input function
Analog input selection	I/V	Selection and switching of voltage analog and current analog	Setting I indicates that the AVI input is a current analog signal. Setting V indicates that AVI input is a voltage analog signal.
Digital input	DI1	Digital input 1	Optocoupler isolation with bipolar input compatibility Input impedance: 3kΩ Voltage range for DI1 to DI4 level inputs: 9 to 30V
	DI2	Digital input 2	
	DI3	Digital input 3	
	DI4	Digital input 4	

Classification	Terminal/ Dial Code Symbol	Terminal/Dial Code Name	Function Declaration
Communication joggle	485+	Modbus communication interface	RS485 positive terminal
	485-	Modbus communication interface	RS485 negative terminal
Relay output	RA-RC	Normally open	Single relay output capacity: 250Vac/3A; 30Vdc/3A
RJ45	RS485	External keyboard interface	External keyboard and keyboard interface, connectable via standard Ethernet cable

6.3.3 Distribution Wiring Considerations

AI simulation input terminal:

Since weak analog voltage signals are highly susceptible to external interference, shielded cables are typically required, and the wiring distance should be kept as short as possible, not exceeding 20 meters (see Figure 3-5). In cases where analog signals are severely interfered with, filter capacitors or ferrite cores should be added at the signal source side.

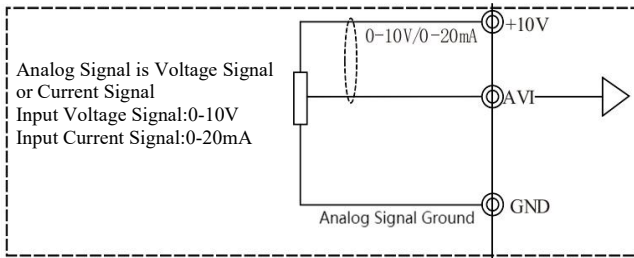

Figure 6-4: Schematic Wiring Diagram of Analog Input Terminal

Version A DI digital input terminal:

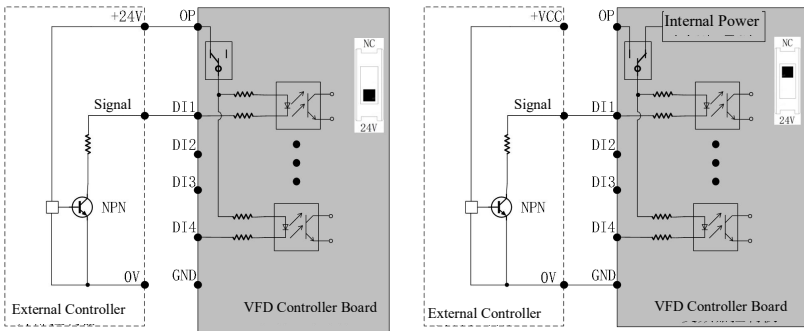

Figure 6-5: Wiring Diagram of Digital Input Terminal in Two Different Modes

Note: When the selector is set to 24V, the external OP signal must be connected to an external 24V power supply. When the selector is set to NC, the OP signal can remain unconnected, and the VFD's GND terminal must be connected to the external controller's GND.

For external power supply, standard IO ports (DI1 ~ DI4) require a voltage range of 9~30V. Shielded cables are generally required, and the wiring distance should be kept as short as possible, not exceeding 20 meters. When using active drive mode, necessary filtering measures must be taken to reduce power crosstalk. Contact control is recommended.

Chapter 7 Display and Operation

7.1 Display and Operation Overview

The drive operation and display area is divided into four sections. Refer to the figure and table below for each section's function.

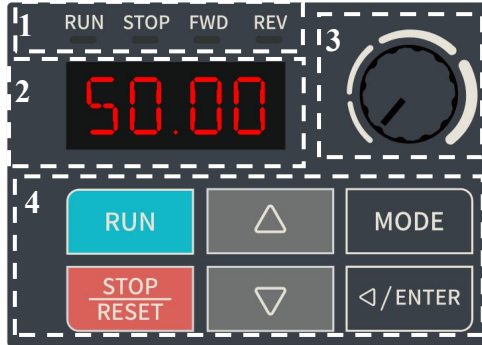

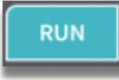



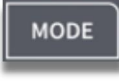



Figure 7-1: Operation and Display Partition Diagram

Table 7-1: Operation and Display of Regional Function Tables

Item	Area	Function	Key/Display Schematic	Corresponding Features
1	Drive status display area	Indicates the current operating status of the VFD. Refer to the table below for details.		Running status indicator Light: Running Off: Not in operation Flash: Acceleration in progress
				Stop status indicator Light: Stop Dying: Not in a shutdown state Flicker: During shutdown
				Forward state indicator Bright: Forward rotation Extinction: Non-regular operation Flash: Switching between forward and reverse
				Inversion status indicator Light: Reverse operation Mute: Non-reversal operation Flash: Switching from reverse to forward
			All lights flash simultaneously	Fault/Warning status indicator
2	Main display area	Displays the drive's function code, frequency, current, voltage, and fault status.	Refer to the table below for the comparison between display codes and actual data	

Item	Area	Function	Key/Display Schematic	Corresponding Features
3	Frequency setting knob	Adjust the drive output frequency		When VR is the default frequency command source, rotating clockwise increases the frequency command while counterclockwise decreases it.
4	Key area	Display interface switching, parameter settings, and VFD control		Use the numeric keypad to run commands.
				When the VFD is running and the operation command comes from the numeric keypad, this function stops the operation. When the VFD is in fault mode, this function performs reset operations (only for resettable faults/warnings). When the command is not executed via numeric keypad, the STOP button's functionality is determined by whether the F7-27 parameter selection is valid.
				The monitoring interface displays the frequency. When the frequency command source is Up/Down to modify the frequency, this function is used to increase the frequency. When setting the parameter interface, use to increase the current parameter group, parameter members, and parameter values.
				The monitoring interface displays the frequency. When the frequency command source is Up/Down to modify the frequency, it is used to reduce the frequency operation. Use this interface to reduce the current parameter group, members, and values.
				When using the monitoring interface, this function switches to the parameter setting interface. Use this to return to the parent menu when setting parameters.

Item	Area	Function	Key/Display Schematic	Corresponding Features
				<p>The monitoring interface allows switching between display modes and setting parameters including frequency (Hz), bus voltage (V), operating frequency (Hz), current display (A), and rotational speed (rpm).</p> <p>The parameter settings interface opens the next-level menu (parameter group parameter member parameter content)</p> <p>When modifying the parameter content interface, short press to shift (adjust the cursor position; if a 5-digit number is displayed, the cursor moves to the 5th digit, and the value shifts one digit to the right), and long press to save the parameter.</p>

7.2 Display

7.2.1 Comparison between Display Codes and Actual Data

Table 7-2: Display Code and Actual Data Comparison Table Actual Display Comparison

LED Display	Real Data	LED Display	Real Data	LED Display	Real Data
0	0	1	1	2	2
3	3	4	4	5	5
6	6	7	7	8	8
9	9	A	A	b	b

LED Display	Real Data	LED Display	Real Data	LED Display	Real Data
	C		d		E
	F		U		H
	L		-		c
	h		n		o
	P		r		t
	u		J		y

Chapter 8 Fault Diagnosis and Countermeasures

8.1 Fault Alarm and Countermeasures

During system operation, if a fault occurs, the VFD will immediately protect the motor by halting output, while the corresponding VFD fault relay contacts activate. The VFD panel displays the fault code, with the corresponding fault type and common troubleshooting methods detailed in the table below. The table is provided for reference only; do not attempt repairs or modifications without authorization. If the fault cannot be resolved, please contact our company or product agent for technical support.

Table 8-1: Fault Alarm and Countermeasures

Fault Name	Panel Display	Troubleshooting	Fault Handling Countermeasures
Accelerating flow	Er04	<ol style="list-style-type: none"> 1. The VFD output circuit is grounded or short-circuited. 2. Incorrect motor parameters 3. The acceleration time is too short 4. Improper V/F torque boost or curve 5. The input voltage is too low. 6. Start the rotating motor 7. Sudden load during acceleration 8. VFD selection is underdimensioned 	<ol style="list-style-type: none"> 1. Eliminate peripheral faults 2. Check parameters 3. Increase acceleration time 4. Adjust V/F to increase torque or curve 5. Adjust the voltage to the normal range 6. Select either speed-tracking startup or wait for the motor to stop before restarting 7. Cancel sudden load 8. Select a VFD with higher power rating
Overflow during deceleration	Er05	<ol style="list-style-type: none"> 1. The VFD output circuit is grounded or short-circuited. 2. Incorrect motor parameters 3. Insufficient deceleration time 4. The input voltage is too low. 5. Sudden load during deceleration 6. No brake unit or brake resistor 7. Excessive flux brake gain 	<ol style="list-style-type: none"> 1. Eliminate peripheral faults 2. Increase the deceleration time 3. Adjust the voltage to the normal range 4. Cancel sudden load 5. Installation of braking units and resistors 6. Reducing magnetic flux braking gain
Overcurrent in constant speed operation	Er06	<ol style="list-style-type: none"> 1. The VFD output circuit is grounded or short-circuited. 2. Incorrect motor parameters 3. The input voltage is too low. 4. Whether there is a sudden load in operation 5. VFD selection is too small 	<ol style="list-style-type: none"> 1. Eliminate peripheral faults 2. Check parameters 3. Adjust the voltage to the normal range 4. Cancel sudden load 5. Select a VFD with higher power rating

Fault Name	Panel Display	Troubleshooting	Fault Handling Countermeasures
Overvoltage during acceleration	Er08	<ol style="list-style-type: none"> 1. The input voltage is too high. 2. External forces accelerate motor operation during acceleration 3. Insufficient acceleration time 4. No brake unit or brake resistor 5. Incorrect motor parameters 	<ol style="list-style-type: none"> 1. Adjust the voltage to the normal range 2. Disengage the auxiliary power or install a brake resistor 3. Increase acceleration time 4. Installation of brake unit and resistance 5. Check parameters
Overvoltage during deceleration	Er09	<ol style="list-style-type: none"> 1. The input voltage is too high. 2. External forces may drag the motor during deceleration. 3. Insufficient deceleration time 4. No brake unit or brake resistor 	<ol style="list-style-type: none"> 1. Adjust the voltage to the normal range 2. Disengage the auxiliary power or install a brake resistor 3. Increase the deceleration time 4. Installation of brake unit and resistance
Overvoltage during constant speed operation	Er10	<ol style="list-style-type: none"> 1. The input voltage is too high. 2. External forces accelerate motor operation during acceleration 	<ol style="list-style-type: none"> 1. Adjust the voltage to the normal range 2. Disengage the auxiliary power or install a brake resistor
Undervoltage fault	Er12	<ol style="list-style-type: none"> 1. Instant power outage 2. The input voltage of the VFD exceeds the specified range. 3. Bus voltage is abnormal 4. Rectifier bridge and buffer resistor malfunction 5. Drive board malfunction 6. Abnormalities in the control panel 	<ol style="list-style-type: none"> 1. Reset failure 2. Adjust the voltage to the normal range 3. Seeking technical support
Drive overload fault	Er13	<ol style="list-style-type: none"> 1. Is the load excessive or has the motor stalled 2. VFD selection is too small 	<ol style="list-style-type: none"> 1. Reduce the load and inspect the motor and mechanical components 2. Select a VFD with higher power rating
Motor overload fault	Er14	<ol style="list-style-type: none"> 1. Is the motor protection parameter F9-01 properly configured 2. Is the load excessive or is the motor experiencing a stall 3. VFD selection is too small 	<ol style="list-style-type: none"> 1. Set this parameter correctly 2. Reduce the load and inspect the motor and mechanical components 3. Select a VFD with higher power rating
Drive overheating	Er15	<ol style="list-style-type: none"> 1. Excessive ambient temperature 2. Air duct blockage 3. The fan is damaged. 4. Module thermistor is damaged 5. VFD module failure 	<ol style="list-style-type: none"> 1. Reduce ambient temperature 2. Clean the air duct 3. Replace the fan 4. Replace the thermistor 5. Replace the VFD module

Fault Name	Panel Display	Troubleshooting	Fault Handling Countermeasures
Software overload	Er16	<ol style="list-style-type: none"> Are the F7-61 and F7-62 parameter settings appropriate The load is too heavy or the motor is locked up. The VFD is too small 	<ol style="list-style-type: none"> If software overcurrent is not required, disable this fault logic by pressing F9-21=0. The overcurrent judgment thresholds and response times for F7-61 and F7-62 can be appropriately increased. Reduce the load and inspect the motor and mechanical components. Select the appropriate power VFD
Current detection error	Er17	<ol style="list-style-type: none"> Check if the internal wiring of the VFD is loose Check if the current detection device is functioning properly Check if the main control board or driver board is functioning properly 	<ol style="list-style-type: none"> Check the wiring Seeking technical support
Input phase defect error	Er23	<ol style="list-style-type: none"> The three-phase input power supply is abnormal Drive board malfunction Lightning protection panel malfunction Main control board malfunction 	<ol style="list-style-type: none"> Check and resolve issues in peripheral circuits Seeking technical support
Output phase loss error	Er24	<ol style="list-style-type: none"> The lead wire from the VFD to the motor is faulty. Three-phase output imbalance of the VFD during motor operation Drive board malfunction Module Error 	<ol style="list-style-type: none"> Eliminate peripheral faults Check the motor's three-phase windings for normal operation and troubleshoot any faults. Seeking technical support
Parameter read and write error	Er25	EEPROM chip damage	Replace the main control board
Communication error	Er27	<ol style="list-style-type: none"> Is the host computer operational? Check if the communication wiring is normal Is the F8 communication parameter group correct 	<ol style="list-style-type: none"> Check the upper computer wiring and other components. Check the communication wiring Verify the parameters of F8 group
External fault	Er28	<ol style="list-style-type: none"> Input external normally open or normally closed fault signals through the multifunctional DI terminal 	<ol style="list-style-type: none"> Fault reset

Fault Name	Panel Display	Troubleshooting	Fault Handling Countermeasures
Customize fault 1	Er30	1. User-defined fault 1 signal input through the multifunction terminal DI	1. Reset
Customize fault 2	Er31	2. User-defined fault 2 signal input through the multifunction terminal DI	1. Reset
Run time PID feedback loss	Er32	1. The PID feedback value is lower than the setpoint of FA-13.	1. Check the feedback signal or reset the FA-13
Quick rate limiting	Er33	1. Overload or locked rotor 2. The acceleration time is too short	1. Reduce the load or replace with a higher-power VFD 2. Appropriately prolong the acceleration time
Dropout fault	Er34	1. When the load shedding detection condition is met, refer to F9-28-F9-30 for specific usage.	1. Reset or reconfigure detection conditions
Input power error	Er35	1. The input voltage is outside the specified range 2. Excessive on/off cycles	1. Adjust input voltage 2. Extend the power-on and power-off cycles
Parameter storage unusual	Er37	Communication abnormality between DSP and EEPROM chip	1. Replace the main control board 2. Seeking manufacturer services
Running time arrive	Er39	1. The VFD's current operating time exceeds the F7-38 preset value.	1. Reset
Cumulative run time to arrive	Er40	1. Cumulative runtime reaches the preset value F7-20	1. Use the parameter initialization function 2. Clear the recording time or reset the cumulative running time
Switch motor during operation	Er42	Switching motor through terminals during operation	Switch the motor after the shutdown
Motor overspeed	Er43	1. The speed detection time F9-34 setting is unreasonable 2. No motor is connected when operating in open-loop vector mode	1. The control mode switches to VF mode when no motor is connected. 2. Reset F9-34 parameters

Fault Name	Panel Display	Troubleshooting	Fault Handling Countermeasures
Abnormal current detected before startup	Er45	<ol style="list-style-type: none"> 1. Motor wiring error; 2. Whether the motor wiring is poorly insulated causes the output short circuit 3. Check for motor burnout or insulation aging; 4. Malfunction due to interference 5. The motor cable has a long wiring length; 6. Hardware failure. 	<ol style="list-style-type: none"> 1. Check and resolve issues in peripheral circuits 2. Contact the manufacturer's technical support
Master-slave control communication disconnected	Er46	<ol style="list-style-type: none"> 1. No host is set, but a slave is configured 2. Communication line malfunction or incorrect communication parameters 	<ol style="list-style-type: none"> 1. Configure the host and reset the fault 2. Check the communication cable and communication parameters in Group F8

8.2 Common Faults and Their Solutions

During operation, the VFD may encounter the following faults. Refer to the methods below for basic troubleshooting.

Table 8-2: Common Faults and Troubleshooting

No.	Fault Phenomenon	Possible Reasons	Solutions
1	No display after power-on	<ol style="list-style-type: none"> 1. The grid voltage is either absent or too low. 2. Switching power supply failure on the VFD drive board 3. Rectifier bridge damage 4. Buffer resistor failure in VFD 5. Control board and keyboard malfunction 6. The connection between the control board, drive board, and keyboard is disconnected. 	<ol style="list-style-type: none"> 1. Check the input power supply 2. Check the busbar voltage 3. Seeking manufacturer services
2	Power-on display “Er45” alarm	<ol style="list-style-type: none"> 1. Short circuit between the motor or output line and ground 2. VFD damage 	<ol style="list-style-type: none"> 1. Measure the insulation of the motor and output lines with a megohmmeter. 2. Seeking manufacturer services
3	Frequent Er15 fault reports (module overheating)	<ol style="list-style-type: none"> 1. The carrier frequency is set too high. 2. Fan damage or air duct obstruction 3. Internal components of the VFD are damaged (thermocouple or other) 	<ol style="list-style-type: none"> 1. Reduce the carrier frequency (F0-26) 2. Replace the fan and clean the air duct 3. Seeking manufacturer services

No.	Fault Phenomenon	Possible Reasons	Solutions
4	The motor fails to rotate after the VFD is activated.	<ol style="list-style-type: none"> 1. Motor and motor wire 2. Incorrect VFD parameter settings (motor parameters) 3. Poor contact between the driver board and the control board 4. Drive board failure 	<ol style="list-style-type: none"> 1. Reconfirm the wiring between the VFD and the motor 2. Replace the motor or resolve the mechanical fault 3. Check and reset the motor parameters
5	DI terminal failure	<ol style="list-style-type: none"> 1. Parameter settings are incorrect 2. External signal error 3. The DI dial switch is in the wrong position. 4. Control board malfunction 	<ol style="list-style-type: none"> 1. Check and reset the parameters related to the F5 group 2. Reconnect the external signal line 3. Verify that the DI dial switch's position matches the wiring configuration. 4. Seeking manufacturer services
6	The VFD frequently reports overcurrent and overvoltage faults.	<ol style="list-style-type: none"> 1. Incorrect motor parameter settings 2. Inappropriate acceleration / deceleration time 3. Load fluctuation 	<ol style="list-style-type: none"> 1. Reset motor parameters 2. Set appropriate acceleration and deceleration time 3. Seeking manufacturer services

Appendix A Modbus Communication Protocol

The VFD features RS232/RS485 communication interfaces and supports Modbus protocol. Centralized control can be achieved via computer or PLC, enabling users to configure operation commands, modify or access function code parameters, and monitor the VFD's operational status and fault data through this protocol.

1. Agreement Content

This serial communication protocol defines the data content and transmission format for serial communication. It includes: the host's polling (or broadcast) format; the host's encoding method, which contains function codes for requested actions, transmitted data, and error checks. The slave's response follows the same structure, including action confirmation, returned data, and error checks. If the slave encounters errors during data reception or fails to execute the host's requested actions, it will generate a fault message as a response and send it back to the host.

2. Application Methods

The VFD is connected to a PC/PLC control network with a single master and multiple slaves, which supports RS232/RS485 bus communication.

3. Bus Architecture

(1) Interface method

RS232/RS485 hardware interface

(2) Transmission Method

Asynchronous serial, half-duplex transmission mode. At any given time, only one of the host and slave can send data while the other can only receive data. During serial asynchronous communication, data is transmitted in packets, frame by frame.

(3) Topological structure

A single host with multiple slaves. Slave addresses range from 1 to 247,0, with 0 being a broadcast address. Each slave address in the network must be unique.

4. Agreement Description

The VFD communication protocol is an asynchronous serial master-slave Modbus protocol. In the network, only the host device can initiate protocol communication (referred to as "query/command"). Other devices (slaves) can only respond to the host's "query/command" by providing data or executing corresponding actions based on the host's commands. The host refers to devices such as personal computers (PCs), industrial control systems, or programmable logic controllers (PLCs), while the slave refers to the VFD. The host can communicate with a specific slave individually or broadcast information to all subordinate slaves. For individual host "query/command" requests, all slaves must respond with an information (called a response). However, for broadcast information sent by the host, slaves do not need to provide feedback responses to the host.

5. Communication Frame Structure

The data format of the VFD's Modbus protocol communication is as follows.

In RTU mode, message transmission must begin with a pause interval of at least 3.5 character time. This is most easily implemented using variable character durations at network baud rates (as shown in T1-T2-T3-T4 in the figure below). The first field in the transmission is the device address, using hexadecimal characters 0-9 and A-F. Network devices continuously monitor the network bus, including during pause intervals. Upon receiving the first field (address field), each device decodes it to determine if it is destined for itself. After the final transmission character, a pause of at least 3.5 character time marks the end of the message. A new message can then begin following this pause.

The entire message frame must be transmitted as a continuous stream. If there is a pause exceeding 1.5 character time before the frame completion, the receiving device will refresh the incomplete message and assume the next byte as the address field of a new message. Similarly, if a new message starts within 3.5 character time after the previous message, the receiving device will treat it as a continuation of the earlier message. This would result in an error, as the value in the final CRC field cannot be correct.

RTU frame format :

Frame header START	3.5 character time
Address of device	Address: 1-247 (configured by F8-02)
Command code CMD	03: Read slave parameters; 06: Write slave parameters
Data content DATA (N-1)	Data content : Function code parameter address, function code parameter count, function code parameter value, etc.
DATA (N-2)	
.....	
Data content DATA0	
CRC CHK low bit	Check value: CRC16 checksum. During transmission, the low byte comes first and the high byte comes last. For the calculation method, see the CRC checksum section in this chapter.
CRC CHK high bit	
END	3.5 character time

Command and Data Instructions (CMD and DATA)

Command code: 03H, reads N words (Word), with a maximum of 12 words and N ranging from 1 to 12.

The specific format is as follows

Host command frame

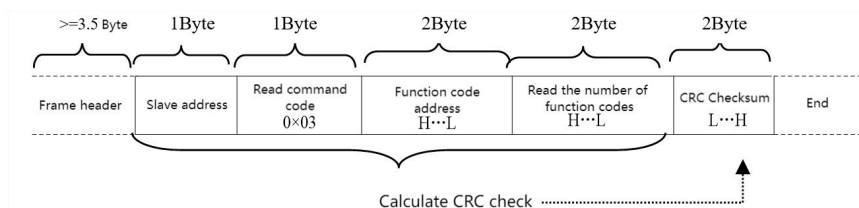

RCAF (Read-Only Answer Frame)

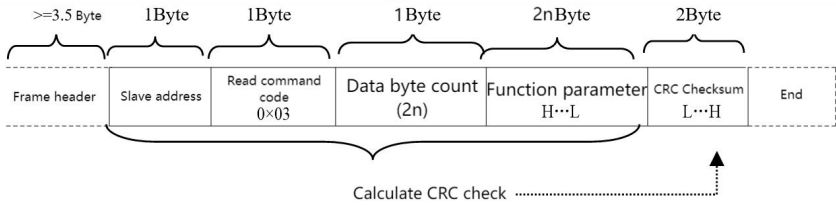

Host write command frame

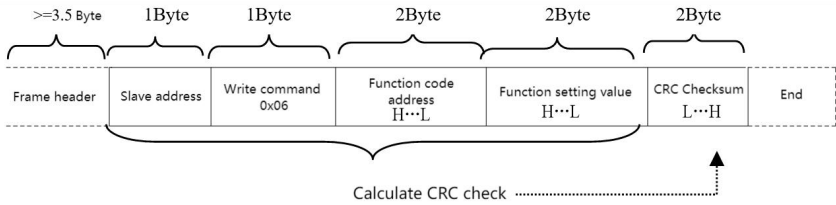

Slave response frame

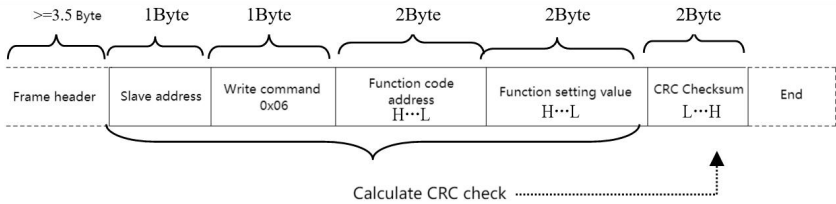

If the slave detects a communication frame error or other reasons causing read/write failure, it will respond with an error frame. Slave reads the error frame:

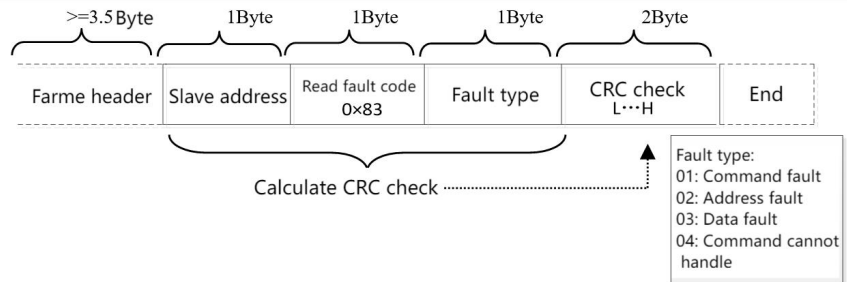

Response error frame from the station

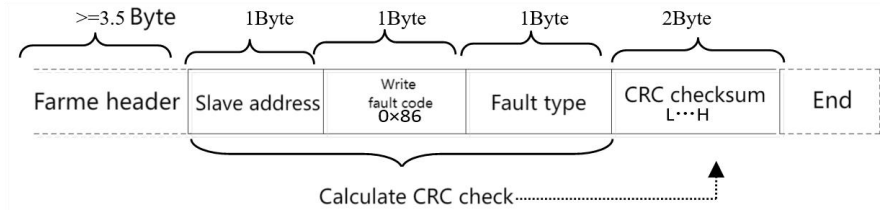

Example: Read the first two parameters of the VFD F0-03, whose slave address F8-02 is 01.

The host sends frames as shown in the figure:

Frame header	Slave address	Read function code	Function code address	Read function code account	CRC check	End
>=3.5 Byte	0x01	0x03	0xF0 0x03	0x00 0x02	0x07 0x0B	

The slave response frame is shown in the figure:

Frame header	Slave address	Read command code	Data byte count	F0_03 parameter value	F0_04 parameter value	CRC check	End
>=3.5 Byte	0x01	0x03	0x04	0x00 0x00	0x00 0x00	0xFA 0x33	

Note: If the write command fails, the reason will be returned.

6. Verification Method (CRC Verification Method)

CRC (Cyclic Redundancy Check) employs the RTU frame format, with messages containing an error detection field based on CRC. This two-byte CRC field, representing a 16-bit binary value, is computed by the transmitting device and appended to the message. The receiving device recalculates the CRC of the received message and compares it with the CRC value in the CRC field. If the two CRC values differ, it indicates a transmission error.

CRC is first set to 0xFFFF, then a function is called to process the 8-bit consecutive bytes in the message with the current register value. Only the 8-bit data in each character is valid for CRC, while the start bit, stop bit, and parity bit are invalid.

During the CRC generation process, each 8-bit character is individually XORed with the register's current value. The result is shifted right, with the most significant bit (LSB) cleared to 0. The LSB is then extracted for verification: if LSB is 1, the register is XORed with its preset value; if LSB is 0, no XOR is performed. This process repeats eight times. After the final bit (the 8th bit) completes, the next 8-bit byte is XORed with the register's current value. The final register value represents the CRC of all bytes in the message.

When adding CRC to a message, the low byte is added first, followed by the high byte. The simple CRC function is as follows:

```

unsigned int crc_chk_value (unsigned char *data_value,unsigned char length) {
    unsigned int crc_value=0xFFFF;
    int i;
    while (length-->0) {
        crc_value^=*data_value++;
    }
}
    
```

```

        for (i=0;i<8;i++)          {          {
            if (crc_value&0x0001)          {
                {
                    crc_value= ( crc_value>>1) ^0xa001;
                }
                else
                {
                    crc_value=crc_value>>1;
                }
            }
        }
    }
    return ( crc_value ) ;
}
    
```

7. Address Definition of Communication Parameters

This section is the content of communication, which is used to control the operation of the VFD, the status of the VFD and the setting of related parameters.

Read and write function code parameters (some function codes are non-modifiable and are reserved for manufacturer use or monitoring purposes):

Function code parameter address marking rules:

Rule for parameter address representation using function code group number and label:

High byte: F0~FF (F group), H0~HF (H group), L0~LF (L group), n0~nF (N group),

P0~PF (P group), 70~7F (U group) low byte: 00~FF

For example, F0-11 is represented by the address F00B.

Notice:

FF group: Parameters cannot be read or modified.

Group U: Read-only, no parameter changes allowed.

Some parameters cannot be modified while the VFD is in operation, while others remain fixed regardless of the VFD's status. When modifying function code parameters, special attention should be paid to their ranges, units, and associated specifications.

Function Code Group Number	Communication Access Address	Modify the Function Code Address in RAM (Write Only)
Groups F0 to FE	0xF000~0xFEFF	0x0000~0x0EFF
Groups H0 to HF	0xA000~0xAFFF	0x4000~0x4FFF
Groups L0 to LF	0xB000~0xBFFF	0x5000~0x5FFF
Groups n0 to nF	0xC000~0xCFFF	0x6000~0x6FFF
Groups U0 and UI	0x70xx, 0x71xx	

Note that frequent EEPROM writes may shorten its lifespan. Therefore, certain function codes in communication mode need not be stored—just update the RAM values.

For the F-group parameter, this function can be implemented by setting the high bit F of the function code address to 0.

For the H-group parameter, this function can be implemented by setting the high bit A of the function code address to 4.

The corresponding function code address is represented as follows:

High byte: 00~0F (F group), 40~4F (A group) Low byte: 00~FF

Example:

Function code F0-11 is not stored in EEPROM, with the address represented as 000B.

This address only supports write operations on RAM and is invalid for read operations.

Shut-down/operation parameters section:

Address	Parametric Description	Address	Parametric Description
0x1000/ 0x9000	1000: *Communication setting value (-10000~10000), (decimal), (unit: 0.01%) readable and writable	0x1014	All pre-calibration voltage (unit: 0.001V), read-only
	9000: Communication set frequency: 0Hz to F0-14 (minimum unit: 0.01Hz), readable and writable	0x1016	Actual linear speed (unit: 1m/min), read-only
0x1001	Set frequency (unit: 0.01Hz), read-only	0x1017	Load speed (unit: custom, refer to F7-31), read-only
0x1002	Run frequency (unit: 0.01Hz), read-only	0x1018	Current power-on time (unit: 1 min), read-only
0x1003	Busbar voltage (unit: 0.1V), read-only	0x1019	Current runtime (unit: 0.1 min), read-only
0x1004	Output voltage (unit: 0.1V), read-only	0x101A	Enter pulse frequency (unit: 1Hz), read-only
0x1005	Output current (unit: 0.1A), read-only	0x101B	Display the main frequency X (unit: 0.01Hz), read-only
0x1006	Output power (unit: 0.1kW), read-only	0x101C	Display the secondary frequency Y (unit: 0.01Hz), read-only
0x1007	DI input flag (unit: 1), read-only	0x101D	Target torque (unit: 0.1%) Set the motor to 100% rated torque, read-only
0x1008	DO output flag (unit: 1), read-only	0x101E	Output torque (unit: 0.1%) Set the motor to 100% rated torque, read-only
0x1009	PID settings (unit: 1), read-only	0x101F	Output torque (unit: 0.1%) Set the VFD's rated current to 100% for read-only mode
0x100A	PID feedback (unit: 1), read-only	0x1020	Torque upper limit (unit: 0.1%) Set the VFD's rated current to 100% for read-only mode
0x100B	All voltage (unit: 0.01V), read-only	0x1021	Separate the target voltage of VF (unit: 1V), read-only
0x100E	PLC steps (unit: 1), read-only	0x1022	VF separation output voltage (unit: 1V), read-only
0x100F	RPM (unit: 1RPM), read-only	0x1023	Reserve, read-only
0x1010	Count value (unit: 1), read-only	0x1024	Motor 1/2 indicator (unit: 1), read-only
0x1011	Enter pulse frequency (unit: 0.01 kHz), read-only	0x1025	Length value input (unit: 1) read-only
0x1012	Feedback speed (unit: 0.1Hz), read-only	0x1027	VFD status (unit: 1), read-only
0x1013	Remaining runtime (unit: 0.1 min), read-only	0x1028	Current fault (unit: 1), read-only

Example 1: Read the operating frequency of the first device: 0x01 0x03 0x10 0x02 0x00 0x01 0x21 0x0A

0x10 0x02 (1002) is the clock frequency address, and 0x00 0x01 (0001) is a data value.

0x21 0x0A (21 0A) CRC checksum

Example 2: Simultaneously read the bus voltage, output voltage, and output current of the first device: 0x01 0x03 0x10 0x03 0x00 0x03 CRC checksum. The data interpretation is similar to Example 1.

Note: The communication setting value is a percentage of a relative value. 10000 corresponds to 100.00%, and -10000 corresponds to -100.00%.

For frequency dimensions data, this percentage is relative to the maximum frequency (F0-14); for torque dimensions data, it is relative to F3-21, F3-23, H3-21, and H3-23.

Note: The D0 output terminal must be configured with the 16 (communication control) function.

Type	Command Address	Command Content
Control command input (only-write)	0x2000	0001: Forward rotation 0002: Reverse rotation 0003: Forward jogging 0004: Reverse jogging 0005: Free stop 0006: Deceleration stop 0007: Fault rest 0008: Fault reset(Fault reset only possible in communication control mode)
Status read (only-read)	0x3000	0001: Forward rotation 0002: Reverse rotation 0003: Stop
Digital output terminal control (only-write)	0x2001	BIT0:RELAY1 output control
VFD fault	0x8000	0000: No fault 0001: Reserved 0002: Reserved 0003: Reserved 0004: Acceleration overcurrent 0005: Deceleration overcurrent 0006: Constant speed overcurrent 0007: Stop overcurrent 0008: Acceleration overvoltage 0009: Deceleration overvoltage 000A: Constant speed overvoltage 000B: Stop overvoltage 000C: Undervoltage fault 000D: VFD overload 000E: Motor overload 000F: Module overheating 0010: Reserved 0011: Current detection fault 0012: Reserved 0013: Reserved 0014: Reserved 0015: Reserved 0016: Reserved 0017: Input phase loss 0018: Output phase loss 0019: EEPROM read/write abnormality 001A: Password input exceeded the limit 001B: Communication abnormality 001C: External fault 001D: Speed deviation too large 001E: User-defined fault 1 001F: User-defined fault 2 0020: PID feedback lost during running 0021: Hardware resistor overload fault 0022: Load drop 0023: Buffer resistor overload fault 0024: Contactor malfunction 0025: Agent running time reached 0026: Motor overheating(reserved)

Appendix B Functional Parameter Table

The function code symbols are as follows:

“☆”: The VFD parameters can be modified during both shutdown and operation (0)

“★”: The VFD is in operation and cannot be modified (1)

“○”: This parameter is a manufacturer parameter and cannot be changed by the user (3)

“●”: Indicates the actual detected value of the VFD or the manufacturer's fixed value, which cannot be modified (2)

The communication address in the function parameter table is written in hexadecimal.

Enhanced function codes: Groups H0 to H3 and L0 to L6, activated by function parameters F7-75.

Function Code	Name	Content	Factory Value	Change	Communication Address
F0 Group-Basic Function Group					
F0-00	Product model	Product model	10H	●	F000
F0-01	Display of GP type in VFD	0: G-type	0	●	F001
F0-02	Rated current	0.1A~3000.0A	Model selection	●	F002
F0-03	Motor control mode	2: VF control	2	★	F003
F0-04	Run command source	0: Command channel of the operation panel (LED off) 1: Terminal command channel (LED on) 2: Communication command channel (LED flashing)	0	★	F004
F0-05	Runtime Up\Down to modify the frequency instruction benchmark	0: Running frequency 1: Set frequency	1	★	F005

Function Code	Name	Content	Factory Value	Change	Communication Address
F0-06	Primary frequency source X selection	0: Up/Down modification frequency stop without memory 1: Up/Down frequency modification with power-off memory 2: All 4: Multi-Stage Speed 5: Simple PLC 6: PID 7: Communication given 9: Up/Down adjustment frequency, shutdown memory, power loss non-memory 11: Panel VR settings	11	★	F006
F0-07	Auxiliary frequency source Y selection	0: Up/Down modification frequency stop without memory 1: Up/Down frequency modification with power-off memory 2: All 4: Multi-Stage Speed 5: Simple PLC 6: PID 7: Communication given 9: Up/Down adjustment frequency, shutdown memory, power loss non-memory 11: Panel VR settings	0	★	F007
F0-08	Auxiliary frequency source Y range selection	0: Relative to maximum frequency 1: Relative to frequency source X 2: Same range as 0 but no negative frequency output for primary and auxiliary	0	☆	F008
F0-09	Auxiliary frequency source Y range	0%~100%	100%	☆	F009

Function Code	Name	Content	Factory Value	Change	Communication Address
F0-10	Frequency source selection	Unit: Frequency source selection 0: Main frequency source X 1: Result of primary and secondary operations (operation relationship determined by the tens digit) 2: Switching between primary frequency source X and auxiliary frequency source Y 3: Switching between main frequency source X and main/auxiliary operation results 4: Auxiliary Frequency Source Y and Switching of Main and Auxiliary Calculation Results Ten: Main and auxiliary operations of frequency source 0: Main + Auxiliary 1: Main-Auxiliary 2: Maximum of both 3: Minimum of both	00	☆	F00A
F0-11	Preset frequency	0.00Hz~maximum frequency F0-14	50.00Hz	☆	F00B
F0-13	Motor running direction selection	0: Same direction as the current motor 1: Opposite to the current motor direction 2: Reverse is prohibited	0	☆	F00D
F0-14	Maximum output frequency	When F0-20=1, the adjustable range is 50.0Hz~1200.0Hz. When F0-20=2, the adjustable range is 50.00Hz~600.00Hz.	50.00Hz	★	F00E
F0-15	Upper limit frequency source	0: Digital given (F0-16) 1: AI1 3: Communication given	0	★	F00F
F0-16	Upper limiting frequency	Lower limit frequency F0-18 ~upper limit frequency F0-14	50.00Hz	☆	F010
F0-17	Upper limit frequency offset	0.00~maximum frequency F0-14	0.00Hz	☆	F011
F0-18	Lower limit frequency	0.00Hz~upper limit frequency F0-16	0.00Hz	☆	F012

Function Code	Name	Content	Factory Value	Change	Communication Address
F0-19	Command source binding selection	0: Unbound 1: Digital frequency setting 2: AI1 4: Multi-stage speed control 5: Simple PLC 6: PID 7: Communication parameters 11: Panel VR settings Unit: Operation panel command binding frequency source selection Ten: Terminal command binding frequency source selection Hundred: Communication command binding frequency source selection Thousand: Reserve	H.000	☆	F013
F0-20	Select decimal frequency	1: 1 decimal place 2: 2 decimal places	2	★	F014
F0-21	Acceleration and deceleration time unit	0:1 second 1:0.1 second 2:0.01 second	1	★	F015
F0-22	Reference frequency for acceleration and deceleration time	0: Maximum frequency (F0-14) 1: Preset frequencies (F0-11) 2: Motor rated frequency (F4-05 or H1-05)	0	★	F016
F0-23	Acceleration time 1	0s~30000s(F0-21=0) 0.0s~3000.0s(F0-21=1) 0.00s~300.00s(F0-21=2)	10.0s	☆	F017
F0-24	Deceleration time 1	0s~30000s(F0-21=0) 0.0s~3000.0s(F0-21=1) 0.00s~300.00s(F0-21=2)	10.0s	☆	F018
F0-25	Over-modulated voltage boost value	0%~10%	3%	★	F019
F0-26	Carrier frequency	2kHz~6.0kHz	Model selection	☆	F01A
F0-27	Carrier frequency adjustment with the temperature	0: Invalid 1: Valid	1	☆	F01B

Function Code	Name	Content	Factory Value	Change	Communication Address
F0-28	Parameter initialization	0: No operation 1: Restore factory settings, excluding motor parameters, recorded data, and frequency decimal points (F0-20) 2: Clear record information	0	★	F01C
F0-29	Select upload and download parameters for LCD	0: No function 1: Download parameters to LCD 2: Upload only F4 group parameters 3: Parameters except for F4 group 4: Upload all parameters	0	☆	F01D
F1 Group-Start/Stop Control					
F1-00	Starting mode	0: Direct start 1: RPM tracking	0	☆	F100
F1-01	Speed tracking mode	0: Start from the shutdown frequency 1: Start from the target frequency 2: Start from the maximum frequency	0	★	F101
F1-02	Maximum current of speed following	30%~150%	100%	★	F102
F1-03	Speed tracking	1~100	20	☆	F103
F1-04	Start frequency	0.00Hz~10.00Hz	0.00Hz	☆	F104
F1-05	Start time holding time	0.0s~100.0s	0.0s	★	F105
F1-06	Start DC braking current	0%~100%	0%	★	F106
F1-07	Time of starting DC braking	0.0s~100.0s	0.0s	★	F107
F1-08	Selection of frequency curve for acceleration and deceleration	0: Straight line 1: S-curve A 2: S-curve B (F1-09~F1-12, with units of 0.01s)	0	★	F108
F1-09	S-curve acceleration start time	0.0%~100.0%	20.0%	★	F109
F1-10	S-curve acceleration end time	0.0%~100.0%	20.0%	★	F10A
F1-11	S curve deceleration start time	0.0%~100.0%	20.0%	★	F10B

Function Code	Name	Content	Factory Value	Change	Communication Address
F1-12	S curve deceleration end time	0.0%~100.0%	20.0%	★	F10C
F1-13	Shut-down mode	0: Slow down and stop 1: Stop freely	0	☆	F10D
F1-14	Start frequency of shutdown DC braking	0.00Hz~F0-14	0.00Hz	☆	F10E
F1-15	Waiting time of shutdown DC brake	0.0s~100.0s	0.0s	☆	F10F
F1-16	Stop brake DC current	0%~100%	0%	☆	F110
F1-17	DC braking time of shutdown	0.0s~36.0s	0.0s	☆	F111
F1-21	Demagnetization time	0.01s ~3.00s	0.50s	★	F115
F1-23	Selection of instant stop-and-go methods	0: Invalid 1: Auto-adjust speed reduction rate 2: Slow down and stop	0	★	F117
F1-24	Instant stop-and-go deceleration time	0.0s ~100.0s	10.0s	★	F118
F1-25	Instant stop-and-go activation voltage	60%~85%	80%	★	F119
F1-26	Instant stop-and-go recovery voltage	85%~100%	90%	★	F11A
F1-27	Instant stop-and-go recovery voltage detection / judgement	0.0s~300.0s	0.3s	★	F11B
F1-28	Instant stop-and-go auto-tuning gain	0~100	40	☆	F11C
F1-29	Instant stop-and-go auto-tuning integral	1~100	20	☆	F11D

Function Code	Name	Content	Factory Value	Change	Communication Address
F2 Group-V/F Control Parameters					
F2-00	V/F curve setting	0: Straight-line VF curve 1: Multi-point VF curve 2: Square VF curve 3: 1.7th power curve 4: 1.5th power curve 5: 1.3th power curve 6: Independent V/F control mode 7: Semi-Independent V/F control mode	0	★	F200
F2-01	Torque boost	0.0%~30.0%	0.0%	☆	F201
F2-02	Torque rise cutoff frequency	0.00Hz~maximum frequency	25.00Hz	★	F202
F2-03	V/F frequency point F1	0.00Hz~F2-05	1.30Hz	★	F203
F2-04	V/F voltage point V1	0.0%~100.0%	5.2%	★	F204
F2-05	V/F frequency point F2	F2-03~F2-07	2.50Hz	★	F205
F2-06	V/F voltage point V2	0.0%~100.0%	8.8%	★	F206
F2-07	V/F frequency point F3	0.00Hz~50.00 Hz	15.00Hz	★	F207
F2-08	V/F voltage point V3	0.0%~100.0%	35.0%	★	F208
F2-09	Slip compensation gain	0.0%~200.0%	50.0%	☆	F209
F2-10	Flux brake gain	0~200	100	☆	F20A
F2-11	Oscillation suppression gain	0~100	Model selection	☆	F20B
F2-13	VF slip compensation time constant	0.02s~1.00s	0.30s	☆	F20D
F2-15	Selection of output voltage source in V/F separation	0: Digital settings (F2-16) 1: All 3: Multi-stage instruction 4: Simple PLC 5: PID 6: Communication setting 100.0% corresponds to the motor's rated voltage	0	☆	F20F

Function Code	Name	Content	Factory Value	Change	Communication Address
F2-16	Digital setting of output voltage for V/F separation	0V~motor rated voltage	0V	☆	F210
F2-17	V/F separation output voltage acceleration time	0.0~3000.0s	1.0s	☆	F211
F2-18	V/F separation output voltage deceleration time	0.0~3000.0s	1.0s	☆	F212
F2-19	Selection of shutdown mode for V/F separation	0: Frequency independent of output voltage deceleration time 1: After the voltage is reduced to 0, the frequency is then decreased	0	☆	F213
F4 Group-First Motor Parameters					
F4-00	Reserved	0: No function	0	●	F400
F4-01	Rated power of motor 1	0.1kW~1000.0kW	Model selection	★	F401
F4-02	Rated voltage of motor 1	1V~1500V	380V	★	F402
F4-03	Number of motor poles	2~64	Model selection	★	F403
F4-04	Rated current of motor 1	0.01A~600.00A (motor rated power ≤30.0kW) 0.1A~6000.0A (motor rated power>30.0kW)	F4-01 confirmed	★	F404
F4-05	Rated frequency of motor 1	0.01Hz~F0-14	50.00 Hz	★	F405
F4-06	Rated speed of motor 1	0RPM~60000RPM	F4-01 confirmed	★	F406
F4-07	No-load current of motor 1	0.01A~F4-04 (motor rated power ≤30.0kW) 0.1A~F4-04 (motor rated power>30.0kW)	Model selection	★	F407
F4-08	Motor stator resistance	0.001Ω~65.535Ω	Model selection	★	F408
F4-09	Rotor resistance of motor	0.001Ω~65.535Ω	Model selection	★	F409
F4-10	Motor 1 mutual inductance	0.1mH~6553.5 mH	Model selection	★	F40A
F4-11	Motor leakage inductance	0.01mH~655.35mH	Model selection	★	F40B

Function Code	Name	Content	Factory Value	Change	Communication Address
F5 Group-Input Terminal					
F5-00	DI1 terminal function	0: No function	1	★	F500
F5-01	DI2 terminal functions	1: Forward drive (FWD) 2: Reverse operation (REV) 3: Three-wire operation	2	★	F501
F5-02	DI3 terminal functions	control 4: Forward rotation point movement (FJOG) 6: Terminal UP 5: Reverse jog (RJOG) 7: Terminal DOWN 8: Free parking 9: Fault reset (RESET) 10: Running paused 11: External fault normally open input 12: Multi-stage instruction terminal 1 13: Multi-stage instruction terminal 2 14: Multi-stage instruction terminal 3 15: Multi-stage instruction terminal 4 16: Acceleration and deceleration selection terminal 1 17: Acceleration and deceleration selection terminal 2 18: Frequency source switching 19: Reset UP/DOWN settings (terminals, keyboard) 20: Run command to switch terminals 21: Acceleration and deceleration are prohibited. 22: PID failure (paused) 23: PLC status reset 24: Frequency swing pause 25: Timed trigger input 26: Immediate DC braking 27: External fault normally closed input 28: Counter input 29: Counter reset 30: Length count input 31: Length counter reset 34: Frequency modification is	9	★	F502
F5-03	DI4 terminal functions		12	★	F503

Function Code	Name	Content	Factory Value	Change	Communication Address
		prohibited 35: Inverted direction of PID action 36: External parking terminal 1 37: Control command switch terminal 2 38: PID integral pause terminal 39: Frequency source X and pre-set frequency switching terminal 40: Frequency source Y and preset frequency switching terminal 41: Switching between Motor 1 and Motor 2 42: Reserved 43: PID parameter switching terminal 45: Emergency stop 46: External parking terminal 2 47: Deceleration DC Braking 48: Reset the runtime 49: Switching between two-wire and three-wire systems 50: Reverse is prohibited 51: User-defined fault 1 52: User-defined fault 2 53: Sleep input			
F5-10	DI terminal filter time	0.000~1.000s	0.010s	☆	F50A
F5-11	Terminal command mode	0: Two-Wire 1 1: Two-Wire 2 2: Three-wire 1 3: Three-wire 2	0	★	F50B
F5-12	Terminal UP/DOWN change rate	0.01Hz/s~100.00Hz/s	1.00Hz/ s	☆	F50C
F5-13	Terminal valid logic 1	0: High level 1: Low level Units: DI1 Tens: DI2 Hundreds: DI3 Thousands: DI4	00000	★	F50D
F5-15	Minimum input value for All	0.00V~10.00V	0.00V	☆	F50F

Function Code	Name	Content	Factory Value	Change	Communication Address
F5-16	AI1 minimum input setting	-100.0%~100.0%	0.0%	☆	F510
F5-17	Maximum input value for AI1	0.00V~10.00V	10.00V	☆	F511
F5-18	AI1 maximum input setting	-100.0%~100.0%	100.0%	☆	F512
F5-19	AI1 input filter time	0.00s~10.00s	0.10s	☆	F513
F5-35	DI1 activation delay time	0.0s~3600.0s	0.0s	☆	F523
F5-36	DI1 delay time	0.0s~3600.0s	0.0s	☆	F524
F5-37	DI2 activation delay	0.0s~3600.0s	0.0s	☆	F525
F5-38	DI2 deactivation delay time	0.0s~3600.0s	0.0s	☆	F526
F5-39	DI3 activation delay	0.0s~3600.0s	0.0s	☆	F527
F5-40	DI3 delay time	0.0s~3600.0s	0.0s	☆	F528
F5-41	AI1 as the DI terminal function selection	0~53, with the same function as standard DI terminals	0	★	F529
F5-44	The effective mode selection of AI as DI terminal	Unit, AI1: 0: High level valid, 1: Low level valid	0x0	☆	F52C
F5-45	AI curve selection	AI multi-point curve selection: Unit: AI1 0:2 point straight line F5-15~F5-19 1: Multi-point curve 1: FE-00~FE-07 2: Multi-point curve 2: FE-08~FE-15	0x0	☆	F52D

Function Code	Name	Content	Factory Value	Change	Communication Address
F6 Group-Output Terminal					
F6-00	Select the output of control board relay RELAY1 (TA/TB/TC)	0: No output 1: VFD operation signal (RUN) 2: Fault output 3: Frequency level detection FDT1 arrived 4: Frequency arrival (FAR) 5: Running at zero speed 6: Motor overload pre-alarm 7: VFD overload pre-alarm 8: PLC cycle completed 9: Cumulative runtime reached 10: Frequency limit in 11: Running ready 13: Upper frequency reached 14: The lower limit frequency is reached. 15: Output in under-voltage state. 16: Communication settings 17: Timer output 18: Running in reverse 19: Reserved 20: Set length to reach 22: Current 1 arrives 23: Frequency 1 arrives 24: Module temperature reaches 25: Unloading in progress 26: Cumulative power-on time reached 27: Timed arrival output 28: The run time has reached 29: Set the count value to reach 30: The specified count value has reached 31: Motor 1, Motor 2 indicators 32: Brake control output 33: Running at zero speed 2 34: Frequency level detection FDT2 reached 35: Zero current state 36: Software current limit exceeded 37: The lower frequency limit is reached, and the system	2	☆	F600

Function Code	Name	Content	Factory Value	Change	Communication Address
		outputs a shutdown signal. 38: Alarm output 39: Reserved 40: All input limit exceeded 41: Reserved 42: Reserved 43: Frequency reached 2 44: The current reaches 2. 45: Fault output.			
F6-21	Main relay T pickup delay	0.0s~3600.0s	0.0s	☆	F615
F6-26	Main relay T release delay	0.0s~3600.0s	0.0s	☆	F61A
F7 Group-Accessibility and Keyboard Display					
F7-00	Jog frequency	0.00Hz~maximum frequency	6.00Hz	☆	F700
F7-01	Jog acceleration time	0.0s~3000.0s	10.0s	☆	F701
F7-02	Jog motion deceleration time	0.0s~3000.0s	10.0s	☆	F702
F7-03	Acceleration time 2	0.0s~3000.0s	10.0s	☆	F703
F7-04	Deceleration time 2	0.0~3000.0s	10.0s	☆	F704
F7-05	Acceleration time 3	0.0~3000.0s	10.0s	☆	F705
F7-06	Deceleration time 3	0.0~3000.0s	10.0s	☆	F706
F7-07	Acceleration time 4	0.0~3000.0s	10.0s	☆	F707
F7-08	Deceleration time 4	0.0~3000.0s	10.0s	☆	F708
F7-09	Jump frequency 1	0.00Hz~maximum frequency	0.00Hz	☆	F709
F7-10	Amplitude of jump frequency 1	0.00Hz~maximum frequency	0.00Hz	☆	F70A
F7-11	Jump frequency 2	0.00Hz~maximum frequency	0.00Hz	☆	F70B
F7-12	Amplitude of jump frequency 2	0.00Hz~maximum frequency	0.00Hz	☆	F70C
F7-15	Forward and reverse dead time	0.0s~3000.0s	0.0s	☆	F70F

Function Code	Name	Content	Factory Value	Change	Communication Address
F7-16	Keyboard knob precision	0: Default 1: 0.1Hz 2: 0.5Hz 3: 1Hz 4: 2Hz 5: 4Hz 6: 5Hz 7: 8Hz 8: 10Hz 9: 0.01Hz 10: 0.05Hz	0	☆	F710
F7-17	Frequency below the lower limit frequency processing	0: Run at the lower frequency limit 1: Shutdown 2: Zero-speed operation	0	☆	F711
F7-18	Droop rate	0.0%~100.0%	0.0%	☆	F712
F7-19	Delay time for shutdown when frequency is below the lower limit	0.0s~600.0s	0.0s	☆	F713
F7-20	Set cumulative runtime	0h~65000h	0h	☆	F714
F7-21	Jog motion priority	0: Invalid 1: Point motion priority mode 2: Point motion priority mode 2 (1) The strobe function remains active during user faults or PID loss faults. (2) Can set shutdown mode and DC braking	1	☆	F715
F7-22	Frequency detection value (FDT1 level)	0.00Hz~maximum frequency	50.00Hz	☆	F716
F7-23	Frequency detection time lag (FDT1 Lag)	0.0%~100.0%	5.0%	☆	F717
F7-24	Frequency arrival detection width	0.0%~100.0%	0.0%	☆	F718
F7-25	Reserved		0	●	F719
F7-26	Fan control	0: The fan is running continuously 1: The fan runs during VFD operation (The fan runs even when the temperature exceeds 40°C)	1	★	F71A
F7-27	STOP/RESET function	0: Valid only when keyboard control is used 1: Shutdown or reset function is available in all control modes	1	☆	F71B

Function Code	Name	Content	Factory Value	Change	Communication Address
F7-28	Quick /JOG key function selection	0: Forward jog movement 1: Forward/Reverse switch 2: Reverse jog movement 3: Switch between panel and remote control	0	★	F71C
F7-29	LED display	0000~0xffff (hexadecimal number) 0000 to 0xffff Bit00: Operating frequency 0001 Bit01: Set frequency 0002 Bit02: Bus voltage 0004 Bit03: Output voltage 0008 Bit04: Output current 0010 Bit05: Output power 0020 Bit06: DI Input Status 0040 Bit07: DO Output Status 0080 Bit08: All voltage 0100 Bit10: PID setpoint 0400 Bit11: PID feedback value 0800 Bit12: Count value 1000 Bit13: Length value 2000 Bit14: Load speed display 4000 Bit15: PLC stage 8000	H.441F	☆	F71D
F7-30	LED shutdown display	1~0x1fff (hexadecimal) Bit00: Set frequency 0001 Bit01: Bus voltage 0002 Bit02: DI input status 0004 Bit03: DO Output Status 0008 Bit04: All Voltage 0010 Bit06: PID setpoint	H.0043	☆	F71E

Function Code	Name	Content	Factory Value	Change	Communication Address
		0040 Bit07: PID feedback value 0080 Bit08: Count value 0100 Bit09: Length value 0200 Bit10: Load speed display 0400 Bit11: PLC stage 0800 Bit13~Bit15: Reserved			
F7-31	load speed velocity coefficient	0.001~655.00	1.000	☆	F71F
F7-32	Radiator temperature	12°C~100°C	Measured value	●	F720
F7-33	Cumulative power-on time	0h~65535h	Measured value	●	F721
F7-34	Cumulative runtime	0h~65535h	Measured value	●	F722
F7-36	Current cycle timer enable selection	0: Disable 1: Enable	0	★	F724
F7-37	Current cycle timer source selection	0: Digital setting F7-38 1: All	0	★	F725
F7-38	Current run time setting	0.0min~6500.0min	0.0min	☆	F726
F7-39	High level timing time	0.0s~6000.0s	2.0s	☆	F727
F7-40	Low level timing time	0.0s~6000.0s	2.0s	☆	F728
F7-41	Enable protection	0: Invalid (direct start command is valid) 1: valid	1	☆	F729
F7-43	Frequency reached detection value 1	0.00Hz~F0-14	50.00Hz	☆	F72B
F7-44	Frequency detection value 1 reaches the width	0.0%~100.0%	0.0%	☆	F72C
F7-45	The current reaches the detection threshold 1	0.0%~300.0%	100.0%	☆	F72D

Function Code	Name	Content	Factory Value	Change	Communication Address
F7-46	Current detection value 1 reaches the width	0.0%~300.0%	0.0%	☆	F72E
F7-49	User password	0~65535	0	☆	F731
F7-50	Whether the jump frequency is effective during acceleration and deceleration	0: Invalid 1: Valid	0	☆	F732
F7-51	Set power-on arrival time	0h~65530h	0h	☆	F733
F7-53	Acceleration time 1/2 switch frequency points	0.00Hz~maximum frequency (F0-14)	0.00Hz	☆	F735
F7-54	Deceleration time 1/2 switch frequency point	0.00Hz~maximum frequency (F0-14)	0.00Hz	☆	F736
F7-55	Frequency detection value (FDT2 level)	0.00Hz~maximum frequency (F0-14)	50.00Hz	☆	F737
F7-56	Frequency detection FDT2 lag value	0.0%~100.0%	5.0%	☆	F738
F7-57	Frequency detection value 2	0.00Hz~maximum frequency (F0-14)	50.00Hz	☆	F739
F7-58	Frequency detection amplitude 2	0.0%~100.0%	0.0%	☆	F73A
F7-59	Zero current detection value	0.0%~300.0%	10.0%	☆	F73B
F7-60	Zero current detection delay time	0.01s~300.00s	1.00s	☆	F73C
F7-61	Output current amplitude detection	20.0%~400.0%	200.0%	☆	F73D
F7-62	Maximum allowable time of software overcurrent	0s~6500.0s	0s	☆	F73E
F7-63	Current reaches the detection threshold 2	20.0%~300.0%	100.0%	☆	F73F

Function Code	Name	Content	Factory Value	Change	Communication Address
F7-64	Current amplitude reaches the detection 2	0.0%~300.0%	0.0%	☆	F740
F7-65	LED operation display parameter 2	0x0~0x1FF Bit04: Motor speed (rpm) 0010 Bit05: AC input current (A) 0020 Bit06: Cumulative runtime (h) 0040 Bit07: Current run time (min) 0080 Bit08: Cumulative power consumption (kWh) 0100 Bit09~Bit15: Reserved	H.010	☆	F741
F7-67	All input voltage lower limit	0.00V~F7-68	2.00V	☆	F743
F7-68	All input voltage upper limit	F7-67~11.00V	8.00V	☆	F744
F7-69	Module temperature reached	0°C~90°C	70°C	☆	F745
F7-70	Output power display correction factor	0.001~3.000	1.000	☆	F746
F7-71	Line speed display correction factor	Linear speed = F7-71*number of HDI pulses sampled per second / Fb-07	1.000	☆	F747
F7-72	Total power consumption (kWh)	0~65535	Measured value	●	F748
F7-73	Performance software version	Performance software version number	##	●	F749
F7-74	Function software version	Function software version number	##	●	F74A
F7-75	Enhance feature parameter display options	0: Hidden enhancement parameter group: H0~H3, L0~L5 1: Display enhanced function parameter group: H0 to H3, L0~L5	0	☆	F74B

Function Code	Name	Content	Factory Value	Change	Communication Address
F7-76	Motor speed display correction factor	0.0010~6.0000	1.0000	☆	F74C
F8 Group-Communication Parameters					
F8-00	Baud rate setting	3: 2400BPS 4: 4800BPS 5: 9600BPS 6: 19200BPS	5	☆	F800
F8-01	Data format	0: No parity <8, N, 2> 1: Even parity <8, E, 1> 2: Odd parity <8, O, 1> 3: No parity 1<8, N, 1>	0	☆	F801
F8-02	Communication address	0 ~ 247 (0 is the broadcast address)	1	☆	F802
F8-03	Answering time	0ms~30ms	2ms	☆	F803
F8-04	Communication timeout time	0.0s~30.0s	0.0s	☆	F804
F8-05	Select communication format	0: Standard ModbusRTU protocol 1: Non-standard ModBusRTU protocol	0	☆	F805
F8-06	485 terminal function	0: Default 485 communication function 1: The backend software monitoring function is active, and the 485 communication function is unavailable 2: External keyboard communication function is enabled. The 485 communication function is unavailable.	0	☆	F806
F9 Group-Fault And Protection					
F9-00	Motor overload protection selection	0: Prohibited 1: Allow	1	☆	F900
F9-01	Motor overload protection gain	0.10~10.00	1.00	☆	F901
F9-02	Motor overload warning coefficient (%)	50%~100%	80%	☆	F902
F9-03	Overspeed stall protection gain	000~100	030	☆	F903
F9-04	Overvoltage stall protection voltage	200.0~1250.0V	380.0V	★	F904
			760.0V	★	
			1150.0V	★	

Function Code	Name	Content	Factory Value	Change	Communication Address
F9-05	VF overcurrent stall protection gain	0~100	20	☆	F905
F9-06	VF overcurrent stall protection current	50%~200%	150%	★	F906
F9-07	VF weak magnetic region overcurrent stall protection coefficient	50%~200%	100%	★	F907
F9-08	Allowable rise limit of overspeed stall	0.0%~50.0%	10.0%	☆	F908
F9-11	Number of automatic fault reset	0~20	0	☆	F90B
F9-12	Selection of fault relay action during automatic fault reset	0: No action 1: Action	0	☆	F90C
F9-13	Fault auto reset interval	0.1s~100.0s	1.0s	☆	F90D
F9-14	Select input phase enable	0: Invalid 1: Valid	1	☆	F90E
F9-15	Output phase loss enable selection	0: Invalid 1: Valid	1	☆	F90F
F9-17	Automatic reset selection for undervoltage fault	0: Manual reset required after under-voltage fault 1: The bus voltage automatically resets after a low-voltage fault.	0	☆	F911
F9-18	Overvoltage suppression mode selection	0: Invalid 1: Overvoltage suppression mode 1 2: Overvoltage suppression mode 2	1	★	F912
F9-19	Over excitation effective state selection	0: Invalid 2: Only the deceleration process is valid 1: Constant speed during operation, effective deceleration process	2	★	F913
F9-20	Overvoltage suppression mode 2 limit	1.0%~150.0%	100.0%	★	F914

Function Code	Name	Content	Factory Value	Change	Communication Address
F9-21	Software overcurrent fault enable	0: Invalid 1: Valid	0	☆	F915
F9-22	Fault protection action 1	0~22202; Unit: Motor overload-Er14 0: Free parking 1: Stop by shutdown method 2: Continue running Ten: Reserved Hundreds: Enter missing phase-Er23 Thousands: Output phase loss-Er24 Ten-thousandth: Parameter read/write error-Er25	00000	☆	F916
F9-23	Fault protection action 2	0~22222; Unit: Communication failure-Er27 0: Free parking 1: Stop by shutdown method 2: Continue running Ten: External fault-Er28 Hundreds: Speed deviation excessive fault-Er29 Thousands: User-defined fault 1-Er30 Ten-thousandth: User-defined fault 2-Er31	00000	☆	F917
F9-24	Fault protection action 3	0~22022; Unit: PID feedback loss during operation-Er32 0: Free parking 1: Stop by shutdown method 2: Continue running Ten: Drop load failure-Er34 Hundreds: Software overcurrent-Er16 Thousands: The current consecutive run time has reached-39 Ten-thousandth: Running time reached-Er40	00000	☆	F918

Function Code	Name	Content	Factory Value	Change	Communication Address
F9-26	Fault continuation frequency selection	0: Run at the current frequency 1: Run at the set frequency 2: Operate at the upper limit frequency 3: Operate at the lower limit frequency 4: Operate at the standby frequency setting F9-27	1	☆	F91A
F9-27	Abnormal standby frequency setting value	0.0%~100.0%	100.0%	☆	F91B
F9-28	Drop out protection selection	0: Invalid 1: Valid	0	☆	F91C
F9-29	Dropout detection level	0.0%~80.0%	20.0%	★	F91D
F9-30	Dropout detection time	0.0s~100.0s	5.0s	☆	F91E
F9-31	Excessive speed deviation detection value	0.0%~100.0%	20.0%	☆	F91F
F9-32	Time of detecting excessive speed deviation	0.0s~100.0s	0.0s	☆	F920
F9-33	Over speed detection value	0.0%~100.0%	20.0%	☆	F921
F9-34	Over-speed detection time	0.0s~100.0s	2.0s	☆	F922
F9-35	Current coefficient of motor overload protection	100%~200%	100%	☆	F923
F9-41	Ground short circuit protection before running	0: Invalid 1: Valid	1	☆	F929
FA Group-PID Function					
FA-00	PID given source	0: PID function code FA-01 1: All 3: Communication given 5: Multiple instructions given 6: Up/Down modification of FA-01 (valid when F0-06=6)	0	☆	FA00
FA-01	PID digital setpoint	0.0%~100.0%	50.0%	☆	FA01
FA-02	PID given ramp time	0.00s~650.00s	0.00s	☆	FA02

Function Code	Name	Content	Factory Value	Change	Communication Address
FA-03	PID feedback source	0: All 3: Communication given	0	☆	FA03
FA-04	PID application direction	0: Positive action 1: Negative action	0	☆	FA04
FA-05	PID given feedback range	0~65535	1000	☆	FA05
FA-06	Proportional gain P	0.0~100.0	50.0	☆	FA06
FA-07	Integration time I	0.01s~10.00s	0.50s	☆	FA07
FA-08	Derivative time D	0.000s~10.000s	0.000s	☆	FA08
FA-09	PID reverse cutoff frequency	0.00~maximum frequency (F0-14)	0.00Hz	☆	FA09
FA-10	Deviation limit	0.0%~100.0%	0.0%	☆	FA0A
FA-11	Derivative limit	0.00%~100.00%	0.10%	☆	FA0B
FA-12	PID feedback filter time	0.00s~60.00s	0.00s	☆	FA0C
FA-13	PID feedback loss detection value	0.0%~100.0%	0.0%	☆	FA0D
FA-14	PID feedback loss detection time	0.0s~3600.0s	0s	☆	FA0E
FA-18	Proportional gain P2	0.0~100.0	20.0	☆	FA12
FA-19	Integration time I2	0.01s~10.00s	2.00s	☆	FA13
FA-20	Derivative time D2	0.000s~10.000s	0.000s	☆	FA14
FA-21	PID parameter switching condition	0No switch 1: DI terminal 2: Auto-switch based on deviation	0	☆	FA15
FA-22	PID parameter switching deviation 1	0.0%~FA-23	20.0%	☆	FA16
FA-23	PID parameter switching deviation 2	FA-22~100.0%	80.0%	☆	FA17
FA-24	PID starter	0.0%~100.0%	0.0%	☆	FA18
FA-25	PID initial value holding time	0.00s~650.00s	0.00s	☆	FA19
FA-26	Maximum positive deviation of the two outputs	0.00%~100.00%	1.00%	☆	FA1A

Function Code	Name	Content	Factory Value	Change	Communication Address
FA-27	Maximum reverse deviation of two outputs	0.00%~100.00%	1.00%	☆	FA1B
FA-28	PID integral property	Units: Separate points 0: Invalid; 1: Valid Ten: Output to the limit value and decide whether to stop integrating 0: Continue integration 1: Stop integration	00	☆	FA1C
FA-29	PID shutdown calculate	0: Do not calculate during shutdown 1: Calculate during shutdown	0	☆	FA1D
FC Group-Multi Stage Instruction and Simple PLC Function					
FC-00	Multi-speed 0	-100.0%~100.0%	0.0%	☆	FC00
FC-01	Multi-speed 1	-100.0%~100.0%	0.0%	☆	FC01
FC-02	Multi-speed 2	-100.0%~100.0%	0.0%	☆	FC02
FC-03	Multi-speed 3	-100.0%~100.0%	0.0%	☆	FC03
FC-04	Multi-speed 4	-100.0%~100.0%	0.0%	☆	FC04
FC-05	Multi-speed 5	-100.0%~100.0%	0.0%	☆	FC05
FC-06	Multi-speed 6	-100.0%~100.0%	0.0%	☆	FC06
FC-07	Multi-speed 7	-100.0%~100.0%	0.0%	☆	FC07
FC-08	Multi-speed 8	-100.0%~100.0%	0.0%	☆	FC08
FC-09	Multi-speed 9	-100.0%~100.0%	0.0%	☆	FC09
FC-10	Multi-speed 10	-100.0%~100.0%	0.0%	☆	FC0A
FC-11	Multi-speed 11	-100.0%~100.0%	0.0%	☆	FC0B
FC-12	Multi-speed 12	-100.0%~100.0%	0.0%	☆	FC0C
FC-13	Multi-speed 13	-100.0%~100.0%	0.0%	☆	FC0D
FC-14	Multi-speed 14	-100.0%~100.0%	0.0%	☆	FC0E
FC-15	Multi-speed 15	-100.0%~100.0%	0.0%	☆	FC0F
FC-16	PLC run mode	0: Stop after a single run 1: Maintain final value on single run 2: Looping continuously	0	☆	FC10
FC-17	PLC power failure memory selection	0: Power off no memory and shutdown no memory 1: Power off memory and shutdown no memory 2: Power off no memory and shutdown memory 3: Power off memory and shutdown memory	0	☆	FC11
FC-18	PLC segment 0	0.0~6500.0	0.0	☆	FC12

Function Code	Name	Content	Factory Value	Change	Communication Address
	runtime				
FC-19	PLC segment 0 accel/decel time selection	0~3 (representing acceleration / deceleration time 1~4 respectively)	0	☆	FC13
FC-20	PLC first section running time	0.0~6500.0	0.0	☆	FC14
FC-21	PLC segment 1 accel/decel time selection	0~3 (representing acceleration / deceleration time 1~4 respectively)	0	☆	FC15
FC-22	PLC section 2 runtime	0.0~6500.0	0.0	☆	FC16
FC-23	PLC segment 2 accel/decel time selection	0~3 (representing acceleration / deceleration time 1~4 respectively)	0	☆	FC17
FC-24	PLC section 3 runtime	0.0~6500.0	0.0	☆	FC18
FC-25	PLC segment 3 accel/decel time selection	0~3 (representing acceleration / deceleration time 1~4 respectively)	0	☆	FC19
FC-26	PLC section 4 runtime	0.0~6500.0	0.0	☆	FC1A
FC-27	PLC segment 4 accel/decel time selection	0~3 (representing acceleration / deceleration time 1~4 respectively)	0	☆	FC1B
FC-28	PLC section 5 runtime	0.0~6500.0	0.0	☆	FC1C
FC-29	PLC segment 5 accel/decel time selection	0~3 (representing acceleration / deceleration time 1~4 respectively)	0	☆	FC1D
FC-30	PLC Section 6 runtime	0.0~6500.0	0.0	☆	FC1E
FC-31	PLC segment 6 accel/decel time selection	0~3 (representing acceleration / deceleration time 1~4 respectively)	0	☆	FC1F
FC-32	PLC segment 7 run time	0.0~6500.0	0.0	☆	FC20
FC-33	PLC segment 7 accel/decel time selection	0~3 (representing acceleration / deceleration time 1~4 respectively)	0	☆	FC21
FC-34	PLC section 8 runtime	0.0~6500.0	0.0	☆	FC22
FC-35	PLC segment 8 accel/decel time selection	0~3 (representing acceleration / deceleration time 1~4 respectively)	0	☆	FC23
FC-36	PLC section 9 runtime	0.0~6500.0	0.0	☆	FC24

Function Code	Name	Content	Factory Value	Change	Communication Address
FC-37	PLC segment 9 accel/decel time selection	0~3 (representing acceleration / deceleration time 1~4 respectively)	0	☆	FC25
FC-38	PLC section 10 runtime	0.0~6500.0	0.0	☆	FC26
FC-39	PLC segment 10 accel/decel time selection	0~3 (representing acceleration / deceleration time 1~4 respectively)	0	☆	FC27
FC-40	PLC section 11 runtime	0.0~6500.0	0.0	☆	FC28
FC-41	PLC segment 11 accel/decel time selection	0~3 (representing acceleration / deceleration time 1~4 respectively)	0	☆	FC29
FC-42	PLC section 12 runtime	0.0~6500.0	0.0	☆	FC2A
FC-43	PLC segment 12 accel/decel time selection	0~3 (representing acceleration / deceleration time 1~4 respectively)	0	☆	FC2B
FC-44	PLC section 13 runtime	0.0~6500.0	0.0	☆	FC2C
FC-45	PLC segment 13 accel/decel time selection	0~3 (representing acceleration / deceleration time 1~4 respectively)	0	☆	FC2D
FC-46	PLC section 14 runtime	0.0~6500.0	0.0	☆	FC2E
FC-47	PLC segment 14 accel/decel time selection	0~3 (representing acceleration / deceleration time 1~4 respectively)	0	☆	FC2F
FC-48	PLC section 15 runtime	0.0~6500.0	0.0	☆	FC30
FC-49	PLC segment 15 accel/decel time selection	0~3 (representing acceleration / deceleration time 1~4 respectively)	0	☆	FC31
FC-50	PLC runtime unit selection	0: s (seconds), 1: h (hours)	0	☆	FC32
FC-51	Multi-speed priority method selection	0: No priority for multi-speed segments 1: Priority for multi-speed segments	1	☆	FC33
FC-52	Multi-stage speed priority accel/decel time time selection	0: Acceleration and deceleration time 1 1: Acceleration and deceleration time 2 2: Acceleration and deceleration time 3 3: Acceleration and deceleration time 4	0	☆	FC34

Function Code	Name	Content	Factory Value	Change	Communication Address
FC-53	Multi-speed FC-00~FC-15 unit selection	0: % 1: Hz	0	☆	FC35
FC-55	Multistage instruction 0 given way	0: Function code FC-00 given 1: All 4: PID 5: Preset frequency (F0-11), UP/DOWN adjustable	0	☆	FC37
FE Group-AI Multi-point Curve Setting					
FE-00	Minimum input for curve 1	-10.00V~FE-02	0.00V	☆	FE00
FE-01	Minimum input corresponding to setting for curve 1	-100.0%~100.0%	0.0%	☆	FE01
FE-02	Input of inflection point 1 for curve 1	FE-00~FE-04	3.00V	☆	FE02
FE-03	Input corresponding to the first inflection point of curve 1	-100.0%~100.0%	30.0%	☆	FE03
FE-04	Input of inflection point 2 for curve 1	FE-02~FE-06	6.00V	☆	FE04
FE-05	Input corresponding to the inflection point 2 of curve 1	-100.0%~100.0%	60.0%	☆	FE05
FE-06	Maximum input of curve 1	FE-04~10.00	10.00V	☆	FE06
FE-07	Maximum input corresponding to setting for curve 1	-100.0%~100.0%	100.0%		FE07
FE-08	Minimum input for curve 2	-10.00~FE-10	0.00V	☆	FE08
FE-09	Minimum input corresponding to curve 2	-100.0%~100.0%	0.0%	☆	FE09
FE-10	Input for inflection point 1 of curve 2	FE-08~FE-12	3.00V	☆	FE0A
FE-11	Input corresponding to the first inflection point of curve 2	-100.0%~100.0%	30.0%	☆	FE0B

Function Code	Name	Content	Factory Value	Change	Communication Address
FE-12	Input of inflection point 2 for curve 2	FE-10~FE-14	6.00V	☆	FE0C
FE-13	Input corresponding to the inflection point 2 of curve 2	-100.0%~100.0%	60.0%	☆	FE0D
FE-14	Maximum input for curve 2	FE-12~10.00V	10.00V	☆	FE0E
FE-15	Maximum input corresponding to setting for curve 2	-100.0%~100.0%	100.0%	☆	FE0F
FE-24	All set jump point	-100.0%~100.0%	0.0%	☆	FE18
FE-25	All set jump range	0.0%~100.0%	0.5%	☆	FE19
FF Group-Manufacturer Parameters					
FF-00	Manufacturer password	0~65535	*****	☆	FF00
H0 Group-Second Motor Parameter Setting					
H0-00	Motor selection	1: Motor 1 2: Motor 2	1	★	A000
H0-01	Second motor control mode	2: VF control	2	★	A001
H0-02	Selection of accel/decel time of second motor	0: Same as the first motor 1: Acceleration and deceleration time 1 2: Acceleration and deceleration time 2 3: Acceleration and deceleration time 3 4: Acceleration and deceleration time 4	0	☆	A002
H1 Group-Second Motor Parameters					
H1-00	Reserved	0: No function	0	★	A100
H1-01	Motor 2 rated power	0.1 kW~1000.0kW	Model selection	★	A101
H1-02	Rated voltage of motor 2	1V~1500V	380V	★	A102
H1-03	Number of motor poles	2~64	Model selection	●	A103
H1-04	Rated current of motor 2	0.01A to 600.00A (motor rated power <=30.0kW) 0.1A to 6000.0A (motor rated power>30.0kW)	H1-01 confirmed	★	A104
H1-05	Motor 2 rated frequency	0.01Hz to maximum frequency (F0-14)	50.00Hz	★	A105

Function Code	Name	Content	Factory Value	Change	Communication Address
H1-06	Rated speed of motor 2	1RPM~60000RPM	H1-01 confirmed	★	A106
H1-07	No-load current of motor 2	0.01A to H1-04 (rated motor power <=30.0kW) 0.1A~H1-04 (motor rated power>30.0kW)	H1-01 confirmed	★	A107
H1-08	Stator resistance of motor 2	0.001ohm~65.535ohm	Model selection	★	A108
H1-09	Rotor resistance of motor 2	0.001ohm~65.535ohm	Model selection	★	A109
H1-10	Mutual inductance of motor 2	0.1mH~6553.5mH	Model selection	★	A10A
H1-11	Inductance of motor 2	0.01mH~655.35mH	Model selection	★	A10B
H2 Group-Second Motor VF Parameter Setting					
H2-00	Torque boost	0.0%~30.0%	0.0%	☆	A200
H2-02	Oscillation suppression gain	0~100	Model selection	☆	A202
L0 Group-System Parameters					
L0-00	Read-only function code selection	0: Invalid 1: Read-only	0	☆	B000
L0-05	Display selection when adjusting up/down	0: Show set value 1: Show current variable value	0	☆	B005
L1 Group-Custom User Function Code					
L1-00	Clear custom function code selection	0: Invalid 1: Valid	0	☆	B100
L1-01	Custom function code 1	uF0-00~uU1-xx	uF0-03	☆	B101
L1-02	Custom function code 2	uF0-00~uU1-xx	uF0-04	☆	B102
L1-03	Custom function code 3	uF0-00~uU1-xx	uF0-06	☆	B103
L1-04	Custom function code 4	uF0-00~uU1-xx	uF0-23	☆	B104
L1-05	Custom function code 5	uF0-00~uU1-xx	uF0-24	☆	B105
L1-06	Custom function code 6	uF0-00~uU1-xx	uF4-00	☆	B106
L1-07	Custom function code 7	uF0-00~uU1-xx	uF4-01	☆	B107
L1-08	Custom function code 8	uF0-00~uU1-xx	uF4-02	☆	B108

Function Code	Name	Content	Factory Value	Change	Communication Address
L1-09	Custom function code 9	uF0-00~uU1-xx	uF4-04	☆	B109
L1-10	Customization code 10	uF0-00~uU1-xx	uF4-05	☆	B10A
L1-11	Custom function code 11	uF0-00~uU1-xx	uF4-06	☆	B10B
L1-12	Custom function code 12	uF0-00~uU1-xx	uF4-12	☆	B10C
L1-13	Custom function code 13	uF0-00~uU1-xx	uF4-13	☆	B10D
L1-14	Custom function code 14	uF0-00~uU1-xx	uF5-00	☆	B10E
L1-15	Custom function code 15	uF0-00~uU1-xx	uF5-01	☆	B10F
L1-16	Custom function code 16	uF0-00~uU1-xx	uF5-02	☆	B110
L1-17	Custom function code 17	uF0-00~uU1-xx	uF6-00	☆	B111
L1-18	Custom function code 18	uF0-00~uU1-xx	uF6-01	☆	B112
L1-19	Custom function code 19	uF0-00~uU1-xx	uF0-00	☆	B113
L1-20	Custom function code 20	uF0-00~uU1-xx	uF0-00	☆	B114
L1-21	Custom function code 21	uF0-00~uU1-xx	uF0-00	☆	B115
L1-22	Custom function code 22	uF0-00~uU1-xx	uF0-00	☆	B116
L1-23	Custom function code 23	uF0-00~uU1-xx	uF0-00	☆	B117
L1-24	Custom function code 24	uF0-00~uU1-xx	uF0-00	☆	B118
L1-25	Custom function code 25	uF0-00~uU1-xx	uF0-00	☆	B119

Function Code	Name	Content	Factory Value	Change	Communication Address
L1-26	Custom function code 26	uF0-00~uU1-xx	uF0-00	☆	B11A
L1-27	Custom function code 27	uF0-00~uU1-xx	uF0-00	☆	B11B
L1-28	Custom function code 28	uF0-00~uU1-xx	uF0-00	☆	B11C
L1-29	Custom function code 29	uF0-00~uU1-xx	uF0-00	☆	B11D
L1-30	Custom function code 30	uF0-00~uU1-xx	uF0-00	☆	B11E
L1-31	Custom function code 31	uF0-00~uU1-xx	uF0-00	☆	B11F
L2 Group-Optimized Control Parameters					
L2-00	Dead zone compensation enable selection	0: No compensation 1: Compensation	1	☆	B200
L2-01	PWM way	0: Asynchronous modulation 1: Synchronous modulation	0	☆	B201
L2-02	PWM seven-stage / five-stage selection	0: Full seven segments 1: Seven segments/five segments automatic switching	0	☆	B202
L2-03	CBC rate limiting enable selection	0: Disabled 1: Enabled	1	☆	B203
L2-04	Braking point	330.0V~2000.0V	360.0V	☆	B204
			690.0V	☆	
L2-05	Under-voltage point	150.0V~900.0V	170.0V	☆	B205
			350.0V	☆	
L2-06	Random PWM depth setting	0~6	0	☆	B206
L2-07	Select 0Hz operation mode	0: No current output 1: Normal operation; 2: Output the braking current F1-16 for the DC braking system during shutdown;	0	☆	B207
L2-08	Selection of low frequency carrier limitation mode	0: Restricted Mode 0 1: Restricted Mode 1 2: Unlimited (all frequency bands use the same carrier)	0	☆	B208

Function Code	Name	Content	Factory Value	Change	Communication Address
L3 Group-AI Correction Parameters					
L3-00	All shows voltage 1	-9.999V~10.000V	3.000V	☆	B300
L3-01	All measured voltage 1	-9.999V~10.000V	3.000V	☆	B301
L3-02	All shows voltage 2	-9.999V~10.000V	8.000V	☆	B302
L3-03	All measured voltage 2	-9.999V~10.000V	8.000V	☆	B303
L4 Group-Master-Slave Control Parameters					
L4-00	Enable master-slave control:	0: Disabled 1: Enabled	0	★	B400
L4-01	Master-slave selection:	0: Master 1: Slave	0	★	B401
L4-02	Host transmission frequency selection:	0: Running frequency 1: Target frequency	0	★	B402
L4-03	Slave follows master command source selection	0: Do not follow 1: Follow	0	★	B403
L4-04	Frequency coefficient of slave receiver	0.00%~600.00%	100.00%	☆	B404
L4-05	Receiving torque coefficient of slave machine	-10.00~10.00	1.00	☆	B405
L4-06	Slave receiving torque offset	-50.00%~50.00%	0.00%	☆	B406
L4-07	Frequency deviation threshold	0.20%~10.00%	0.50%	☆	B407
L4-08	Master-slave communication disconnection detection time	0.00s~10.0s	0.1s	☆	B408
L5 Group-Brake Function Parameters					
L5-00	Brake control enable selection	0: Disabled 1: Enabled	0	★	B500
L5-01	Brake release frequency	0.00Hz~20.00Hz	2.50Hz	★	B501
L5-02	Brake release frequency hold time	0.0s~20.0s	1.0s	★	B502

Function Code	Name	Content	Factory Value	Change	Communication Address
L5-03	Current limit during brake period	50.0%~200.0%	120.0%	★	B503
L5-04	Brake engage frequency	0.00Hz~20.00 Hz	1.50Hz	★	B504
L5-05	Brake engage delay time	0.0s~20.0s	0.0s	★	B505
L5-06	Brake engage frequency holding time	0.0s~20.0s	1.0s	★	B506
L6 Group—Parameters of Sleep/Wake Function					
L6-00	Sleep function selection	0: Sleep function disabled 1: Controlled by digital input DI terminal 2: Controlled by PID setpoint and feedback value 3: Controlled by operating frequency	0	☆	B600
L6-01	Sleep function frequency	0.00Hz~F0-14	0.00Hz	☆	B601
L6-02	Sleep function delay	0.0s~3600.0s	20.0s	☆	B602
L6-03	Wake-up difference	0.0%~100.0% When L6-00=3, the unit is converted to Hz.	10.0%	☆	B603
L6-04	Wake-up delay	0.0s~3600.0s	0.5s	☆	B604
L6-05	Sleep delay frequency output selection	0: PID automatic regulation 1: Sleep frequency L6-01	0	☆	B605

Function Code	Name	Mini Unit	Change	Communication Address	
U0 Group – Fault Record Parameters					
U0-00	Latest fault type	00: No faults Er04: Overcurrent during acceleration	1	●	7000
U0-01	Previous fault type	Er05: Overcurrent during deceleration Er06: Overcurrent in constant speed operation	1	●	7001
U0-02	Second previous fault type	Er08: Overvoltage during acceleration Er09: Overvoltage during deceleration Er10: Overvoltage during constant speed operation Er12: Under-voltage fault Er13: Driver overload fault	1	●	7002

Function Code	Name	Mini Unit	Change	Communication Address
	Er14: Motor overload fault Er15: Driver overheating Er16: Software overcurrent Er17: Current detection failure Er23: Input phase loss failure Er24: Output phase loss failure Er25: EEPROM operation failure Er27: Communication failure Er28: External fault Er30: User-defined fault 1 Er31: User-defined fault 2 Er32: PID feedback loss during operation Er33: Quick rate limiting Er34: Load shedding fault Er35: Input power failure Er37: Parameter storage error Er39: The run time has reached Er40: Cumulative runtime reached Er42: Switch motor in operation Er45: Abnormal current detected before operation Er46: Master-slave control communication disconnected			
U0-03	Last failure frequency	0.01Hz	●	7003
U0-04	Current at last failure	0.01A	●	7004
U0-05	Bus voltage at last failure	0.1V	●	7005
U0-06	Input terminal status during the last failure	1	●	7006
U0-07	Output terminal status during the last fault	1	●	7007
U0-08	Latest status of the faulty VFD	1	●	7008
U0-09	Operation time of the last failure (counting from the power on, minutes)	1min	●	7009
U0-10	Time of the recent failure (counting from the operating time, minutes)	1min	●	700A
U0-13	Previous failure frequency	0.01Hz	●	700D
U0-14	Current at previous failure	0.01A	●	700E
U0-15	Bus voltage during previous fault	0.1V	●	700F
U0-16	Input terminals during the previous failure	1	●	7010
U0-17	Output terminal during the previous failure	1	●	7011
U0-18	VFD state at previous fault	1	●	7012
U0-19	Operation time of the previous failure (counting from the power on, minutes)	1min	●	7013
U0-20	Time of the previous failure (counting from the operating time, minutes)	1min	●	7014
U0-21	Reserved variable		●	7015
U0-22	Reserved variable		●	7016

Function Code	Name	Mini Unit	Change	Communication Address
U0-23	Frequency of the first two faults	0.01Hz	●	7017
U0-24	Current at the first two faults	0.01A	●	7018
U0-25	Bus voltage during the first two faults	0.1V	●	7019
U0-26	Input terminals during the first two failures	1	●	701A
U0-27	Output terminals during the first two failures	1	●	701B
U0-28	Status of the first two faults in the VFD	1	●	701C
U0-29	Operation time of the first two fault (counting from the power on, minutes)	1min	●	701D
U0-30	The time of the first two faults (counting from the operating time, minutes)	1min	●	701E
U1 Group-Application Monitoring Parameters				
U1-00	Running frequency (Hz)	0.01Hz	●	7100
U1-01	Set frequency (Hz)	0.01Hz	●	7101
U1-02	Busbar voltage (V)	0.1V	●	7102
U1-03	Output voltage (V)	1V	●	7103
U1-04	Output current(A)	0.1A	●	7104
U1-05	Output power (kW)	0.1kW	●	7105
U1-06	DI input status, hexadecimal number	1	●	7106
U1-07	DO output status, hexadecimal number	1	●	7107
U1-08	All voltage after correction	0.01V	●	7108
U1-10	PID set value (percentage) * FA-05	1	●	710A
U1-11	PID feedback, PID feedback value (percentage) *FA-05	1	●	710B
U1-12	Count value	1	●	710C
U1-13	Length value	1	●	710D
U1-14	Motor speed	kRPM	●	710E
U1-15	PLC stage, current segment during multi-segment speed operation	1	●	710F
U1-17	Feedback speed, actual motor operating frequency	0.1Hz	●	7111
U1-18	F7-38 remaining time of timing	0.1Min	●	7112
U1-19	All voltage before correction	0.001V	●	7113
U1-22	Load speed display (set load speed during shutdown), refer to F7-31 for usage	User - defined	●	7116
U1-23	Power-on time	1Min	●	7117
U1-24	Running time	0.1Min	●	7118
U1-26	Set communication frequency value	0.01%	●	711A
U1-27	Main frequency display	0.01Hz	●	711B
U1-28	Auxiliary frequency display	0.01Hz	●	711C
U1-33	VF separates the target voltage	1V	●	7121
U1-34	VF separates the output voltage	1V	●	7122
U1-35	Reserved		●	7123
U1-36	Current motor sequence number	1	●	7124
U1-39	VFD operating status: 0: Shutdown, 1: Forward, 2: Reverse, 3: Fault	1	●	7127

Function Code	Name	Mini Unit	Change	Communication Address
U1-40	VFD fault	1	●	7128
U1-41	Agent limited time remaining	1h	●	7129
U1-43	The remaining time of the current stage of PLC	0.1	●	712B
U1-47	Cumulative runtime 1 (cumulative runtime = U1-47 + U1-48)	1h	●	712F
U1-48	Cumulative runtime 2 (cumulative runtime = U1-47 + U1-48)	1min	●	7130